

2.5W Mono Filter-Free Class D Audio Power Amplifier

Description

The AAT5101 is a high efficiency, 2.5W mono class D audio power amplifier. The low noise, filterless PWM architecture eliminates the output filter, reduces the external component count and system cost, and simplifies system design. With high efficiency of up to 92% and the industry lowest 1.35mA quiescent current, it increases battery lifetime and dramatically lowers the junction temperature. The space saving wafer-level chip scale package (WLCSP) and minimum external component requirements make it ideal for cellular phones and PDAs.

With high PSRR, low THD+N, and 91dB SNR, the AAT5101 guarantees clean sound across the wide audio output power range and the full audio frequency domain. Short circuit and thermal protection with self-recovery prevents the device from being damaged during over current conditions.

In cellular phones, the earpiece, speaker phone and melody ringer can each be driven by the AAT5101. Also, proprietary technology successfully suppresses pop and click noise.

Features

- Maximum Battery Life and Minimum Heat
 - 1.35mA Quiescent Current
 - 0.06µA Shutdown Current
 - Up to 92% Efficiency
- Large Output Power Capabilities
 - 1.35W with 8Ω Load and THD+N < 1%
 - 2.5W with 4Ω Load and THD+N < 10%
- Pop and Click Noise Suppression Circuitry
- Thermal and Output Short Circuit Protection with Self-recovery
- High Performance, THD+N of 0.12% at 5V, 8Ω Load and $P_{OUT} = 1.0W$
- Filter-less Capability
- Internally Generated 250 kHz Switching Frequency
- Excellent PSRR and Wide Supply Voltage Range (2.1V to 5.5V)
- Fully Differential Design
- External Gain Configuration Capability
- 9-Pin Wafer-Level Chip Scale Packaging (WLCSP)

Applications

- Cellular Phones
- MP4s
- Notebook Computers
- PDAs
- Portable DVD Players

Typical Application

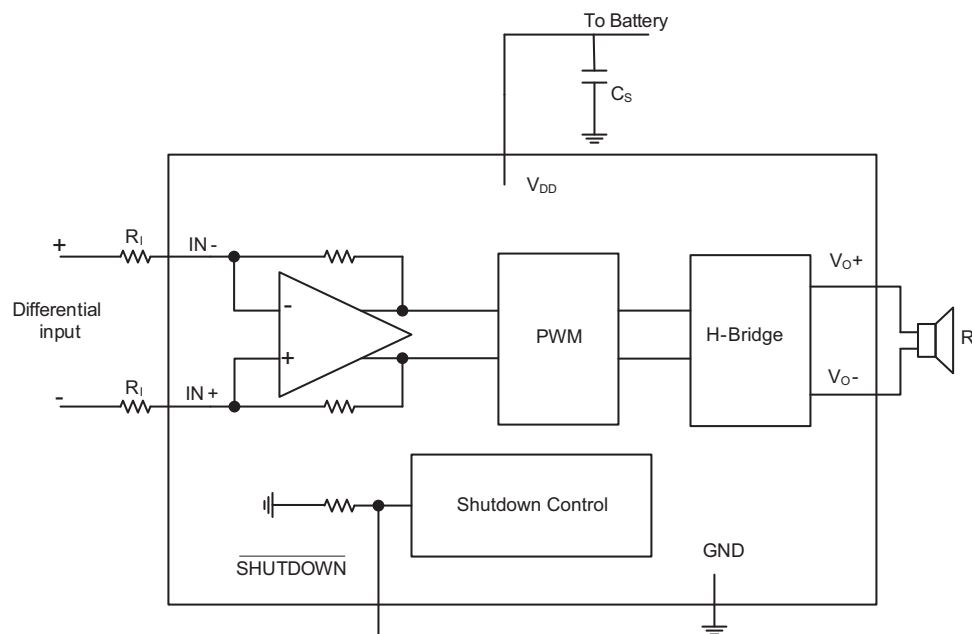

2.5W Mono Filter-Free Class D Audio Power Amplifier
Pin Description

Pin #	Symbol	Type	Description
A1	IN+	I	Positive differential input.
A2	GND	I	Analog ground.
A3	VO-	O	Negative BTL output.
B1	VDD	I	Analog power supply.
B2	PVDD	I	Power supply for internal H-bridge stage.
B3	GND	I	Analog ground.
C1	IN-	I	Negative differential input.
C2	$\overline{\text{SHUTDOWN}}$		The device enters shutdown mode when a low level is applied on this pin. An internal 300k Ω will force the device into shutdown mode if no signal is applied to this pin. It also helps to save space and cost.
C3	VO+	O	Positive BTL output

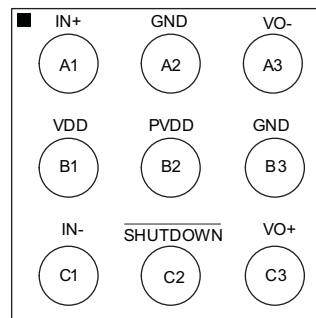
Pin Configuration
**WLCSP-9
(Top View)**

2.5W Mono Filter-Free Class D Audio Power Amplifier
Absolute Maximum Ratings

Symbol	Description	Max	Units
V_{DD}	Supply Voltage	Active Mode	5.5
		Shutdown Mode	6.0
I_{OUT}	Maximum Output Current	1.5	A
T_A	Operating Ambient Temperature	-40 to +85	°C
T_J	Maximum Junction Temperature	165	°C
	Latchup Current @ $T_A = 85^\circ\text{C}$	> 200	mA

Recommended Operating Conditions

Symbol	Description	Min	Max	Units
P_{VDD}, V_{DD}	Supply Voltage	2.1	5.5	V
T_A	Operating Temperature	-40	85	°C

2.5W Mono Filter-Free Class D Audio Power Amplifier
Electrical Characteristics
 $T_A = 25^\circ\text{C}$ unless otherwise noted.

Symbol	Characteristic	Conditions	Min	Typ	Max	Units
V_{DD}	Operating Supply Voltage	$T_A = -40^\circ\text{C}$ to $+85^\circ\text{C}$	2.1		5.5	V
I_Q	Supply Quiescent Current	$V_{DD} = 5.5\text{V}$, No Load		1.72	3.2	mA
		$V_{DD} = 3.6\text{V}$, No Load		1.35		
		$V_{DD} = 2.1\text{V}$, No Load		0.87	2.5	
I_{SD}	Shutdown Current	$V_{DD} = 2.1\text{V}$ to 5.5V		0.06	1	μA
V_{SDIH}	Shutdown Voltage High	$V_{DD} = 3.6\text{V}$	2.0			V
V_{SDIL}	Shutdown Voltage Low	$V_{DD} = 3.6\text{V}$			1.5	V
F_{SW}	Switching Frequency	$V_{DD} = 2.1\text{V}$ to 5.5V	200	250	300	kHz
G	Amplifier Gain	$R_L = 4\Omega$	$285\text{K}\Omega/R_L$	$300\text{K}\Omega/R_L$	$315\text{K}\Omega/R_L$	V/V
R_{DS}	Static Drain-Source On-State Resistance	$V_{DD} = 5.5\text{V}$		300		m Ω
		$V_{DD} = 3.6\text{V}$		350		
		$V_{DD} = 2.1\text{V}$		500		
R_S	Resistance from Shutdown to GND			300		K Ω
T_{ON}	Turn On Time	$V_{DD} = 2.1\text{V}$ to 5.5V		8		ms
T_{OFF}	Turn Off Time	$V_{DD} = 2.1\text{V}$ to 5.5V		8		ms

Operating Characteristics
 $T_A = 25^\circ\text{C}$, Gain = 2V/V, $R_L = 150\text{k}\Omega$ unless otherwise noted.

Symbol	Characteristic	Conditions	Min	Typ	Max	Units	
P_{OUT}	Output Power	THD+N = 10%, $f = 1\text{kHz}$, $R_L = 4\Omega$	$V_{DD} = 5.0\text{V}$		2.80	W	
			$V_{DD} = 3.6\text{V}$		1.41		
			$V_{DD} = 2.5\text{V}$		0.62		
		THD+N = 1%, $f = 1\text{kHz}$, $R_L = 4\Omega$	$V_{DD} = 5.0\text{V}$		2.35		
			$V_{DD} = 3.6\text{V}$		1.14		
			$V_{DD} = 2.5\text{V}$		0.46		
		THD+N = 10%, $f = 1\text{kHz}$, $R_L = 8\Omega$	$V_{DD} = 5.0\text{V}$		1.66		
			$V_{DD} = 3.6\text{V}$		0.84		
			$V_{DD} = 2.5\text{V}$		0.37		
		THD+N = 1%, $f = 1\text{kHz}$, $R_L = 8\Omega$	$V_{DD} = 5.0\text{V}$		1.35		
			$V_{DD} = 3.6\text{V}$		0.68		
			$V_{DD} = 2.5\text{V}$		0.29		
η	Efficiency	$R_L = 8\Omega$, $f = 1\text{kHz}$	$V_{DD} = 5.0\text{V}$, $P_{OUT} = 1.2\text{W}$		92	%	
			$V_{DD} = 3.6\text{V}$, $P_{OUT} = 0.6\text{W}$		91		
		$R_L = 4\Omega$, $f = 1\text{kHz}$	$V_{DD} = 5.0\text{V}$, $P_{OUT} = 2.0\text{W}$		87		
			$V_{DD} = 3.6\text{V}$, $P_{OUT} = 1.0\text{W}$		85		
THD+N	Total Harmonic Distortion + Noise	$R_L = 8\Omega$, $f = 1\text{kHz}$	$V_{DD} = 5.0\text{V}$, $P_{OUT} = 1.0\text{W}$		0.12	%	
		$R_L = 8\Omega$, $f = 1\text{kHz}$	$V_{DD} = 3.6\text{V}$, $P_{OUT} = 0.5\text{W}$		0.21		
		$R_L = 8\Omega$, $f = 1\text{kHz}$	$V_{DD} = 2.5\text{V}$, $P_{OUT} = 0.2\text{W}$		0.26		
SNR	Signal-to Noise Ratio	$V_{DD} = 5.0\text{V}$, $P_{OUT} = 1.0\text{W}$, $R_L = 8\Omega$		91		dB	
CMRR	Common Mode Rejection Ratio	$V_{DD} = 3.6\text{V}$, $V_{IC} = 1\text{Vpp}$	$f = 217\text{Hz}$	-63		dB	
PSRR	Power Supply Ripple Rejection	$V_{DD} = 3.6\text{V}$, Inputs AC-ground with $C_1 = 2.2\mu\text{F}$	$V_{RIPPLE} = 200\text{mVpp}$, $f = 217\text{Hz}$	-60		dB	
Z_I	Input Impedance	$T_A = 25^\circ\text{C}$, Gain = 2V/V, $R_L = 4\Omega$		142	150	158	k Ω

2.5W Mono Filter-Free Class D Audio Power Amplifier

Typical Characteristics^{1, 2}

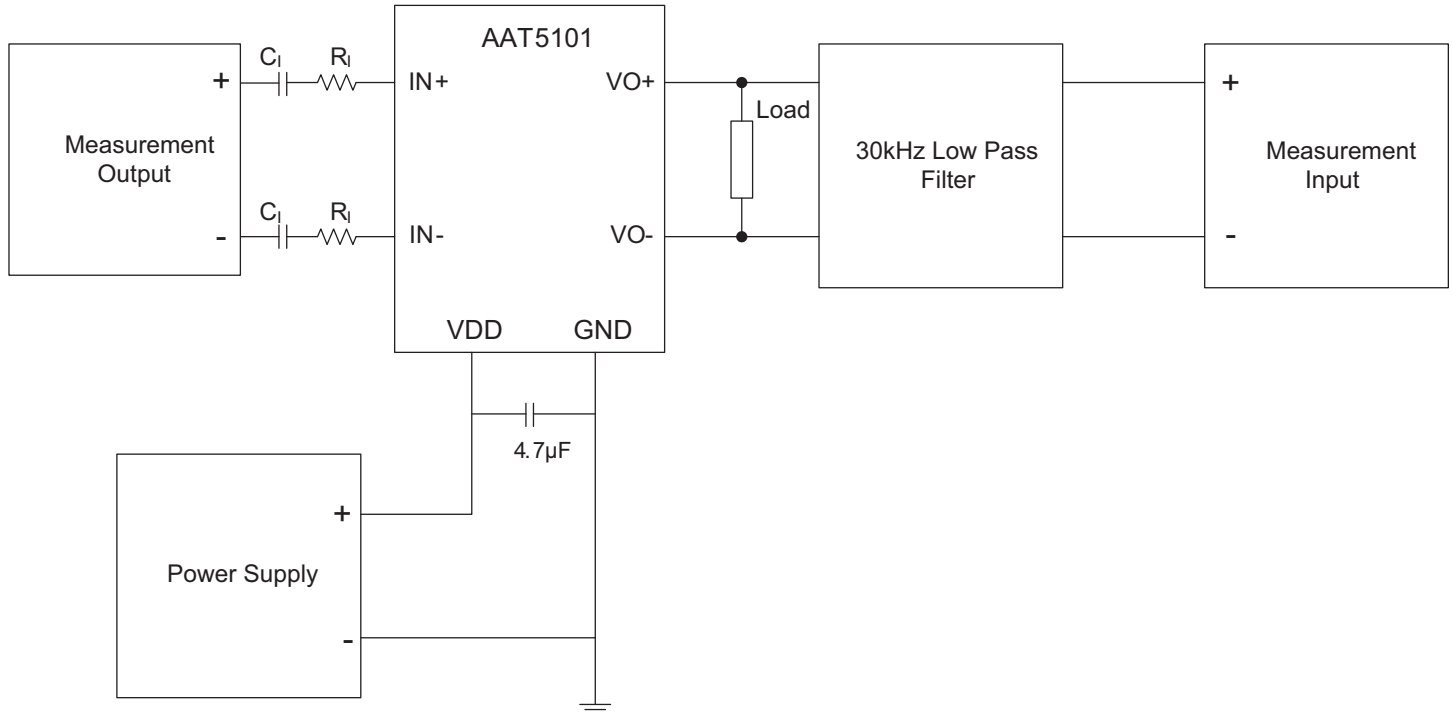

Test Set-up for Typical Characteristics Graphs.

1. A 33µH inductor was placed in series with load resistor to emulate a small speaker for efficiency measurement.
 2. The 30kHz low-pass filter is required even if the analyzer has an internal low-pass filter. An RC low pass filter (100Ω, 47nF) is used on each output for the data sheet graphs.

2.5W Mono Filter-Free Class D Audio Power Amplifier

Typical Characteristics

Efficiency vs. Output Power
(f = 1kHz; R_L = 8Ω + 33μH)

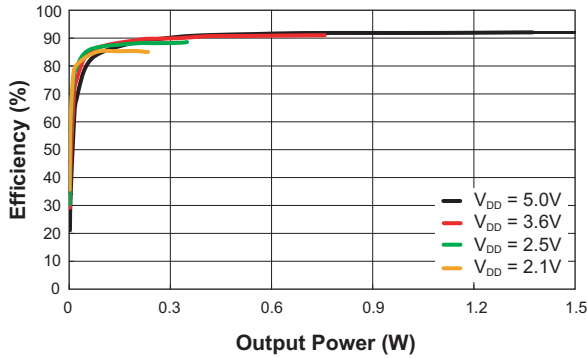

Efficiency vs. Output Power
(f = 1kHz; R_L = 4Ω + 33μH)

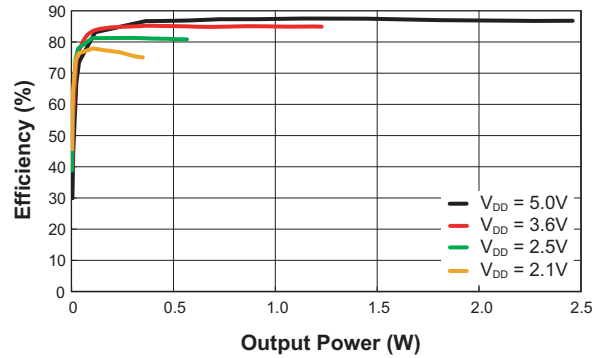

Supply Current vs. Output Power
(f = 1kHz; R_L = 8Ω + 33μH)

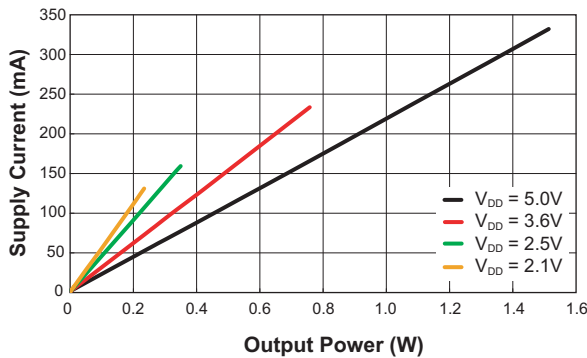

Supply Current vs. Output Power
(f = 1kHz; R_L = 4Ω + 33μH)

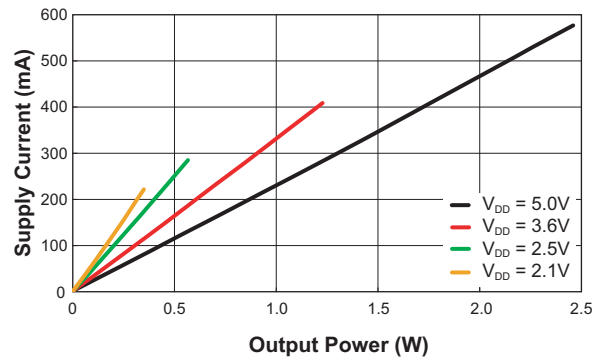

Supply Voltage vs. Quiescent Current

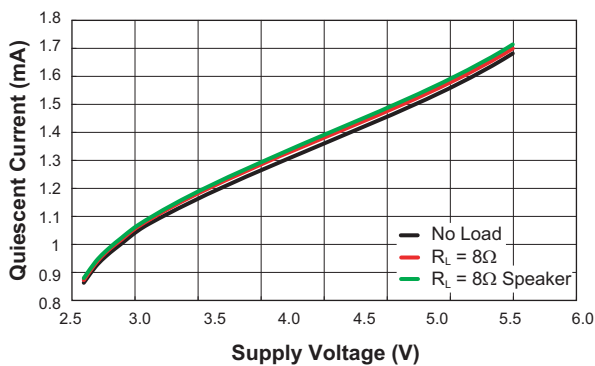

2.5W Mono Filter-Free Class D Audio Power Amplifier

Typical Characteristics

THD+N vs. Output Power
(f = 1kHz; R_L = 8Ω)

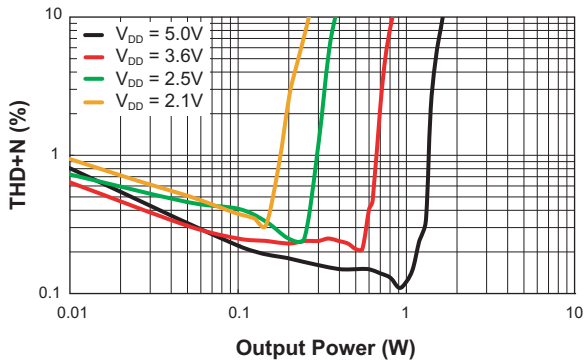

THD+N vs. Output Power
(f = 1kHz; R_L = 4Ω)

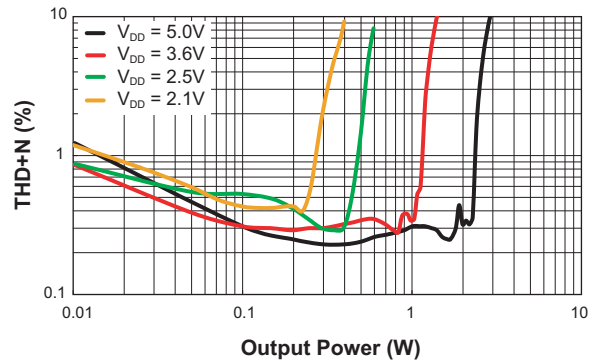

THD+N vs. Frequency
(C₁ = 2.2μF; R_L = 8Ω)

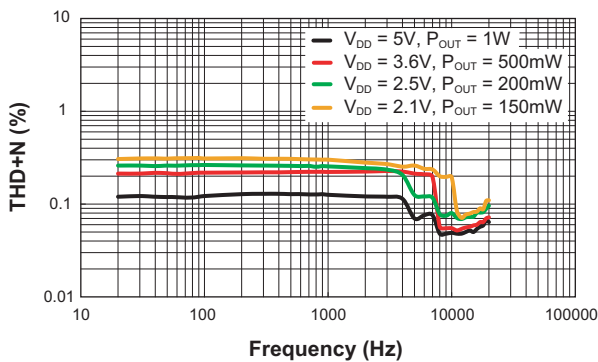

THD+N vs. Frequency
(C₁ = 2.2μF; R_L = 4Ω)

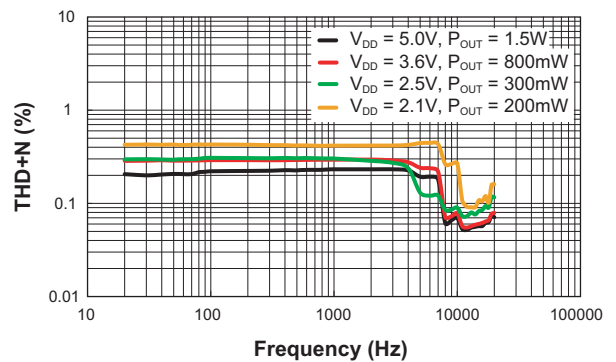

Output Power vs. Supply Voltage
(f = 1kHz; R_L = 8Ω)

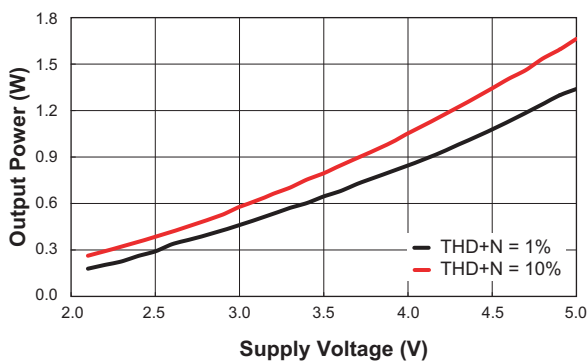

Output Power vs. Supply Voltage
(f = 1kHz; R_L = 4Ω)

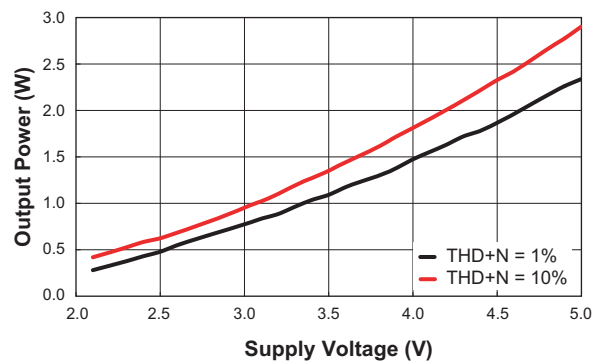

2.5W Mono Filter-Free Class D Audio Power Amplifier

Typical Characteristics

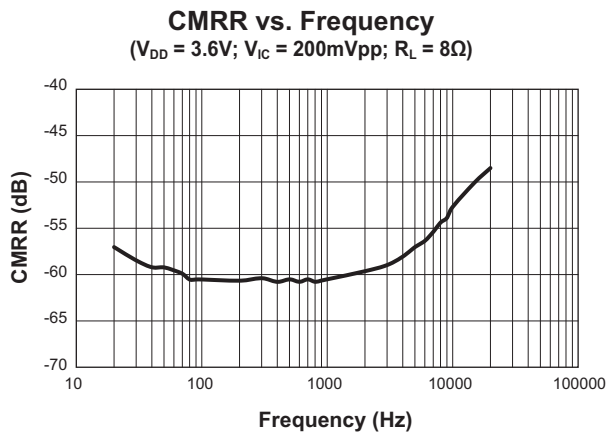
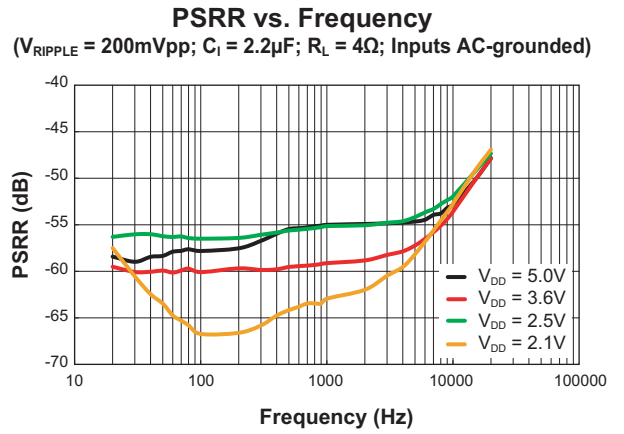
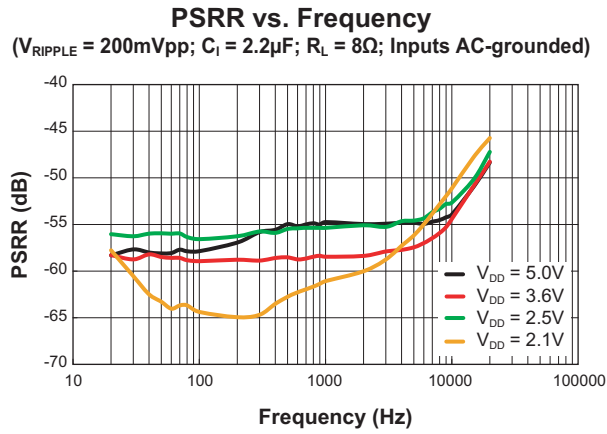

2.5W Mono Filter-Free Class D Audio Power Amplifier

Application Information

Input Resistor (R_I) Selection

The input resistors (R_I) set the gain of the amplifier according to the following equation:

$$\text{Gain} = \frac{300\text{K}\Omega}{R_I}$$

For input resistors (R_I), resistor matching is a very important criteria. The balance of the output around the reference voltage depends on a matched ratio of the resistors. CMRR and PSRR diminish if resistor mismatch occurs. Therefore, it is recommended to use 1% tolerance resistors or better to keep the performance optimized.

Decoupling Capacitor (C_S) Selection

The AAT5101 is a high-performance class-D audio amplifier that requires adequate power supply decoupling to ensure high efficiency and low total harmonic distortion (THD). For decoupling capacitor (C_S), a good low equivalent series resistance (ESR) 4.7 μ F ceramic capacitor is preferred.

Input Capacitor (C_I) Selection

The input capacitors and input resistors form a high-pass filter with the corner frequency, F_c , determined by the following equation. The value of the input capacitor is an important consideration as it directly affects the bass (low frequency) performance of the circuit. Speakers in wireless phones cannot usually respond well to low frequencies, so a high pass filter will be useful in this application.

$$F_c = \frac{1}{2 \cdot \pi \cdot R_I \cdot C_I}$$

Optional Output Filter

The AAT5101 can be designed without an output filter if the traces from the amplifier to the speaker are short. However, to lower radiated emissions as much as possible when used in filter-free mode, a ferrite bead filter can be used. If choosing a ferrite bead, choose one with high impedance at high frequencies, but very low impedance at low frequencies. The MPZ1608S221A1 from TDK is a good choice.

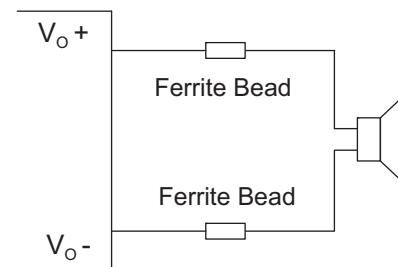

Figure 1: Optional EMI Ferrite Bead Filter.

2.5W Mono Filter-Free Class D Audio Power Amplifier

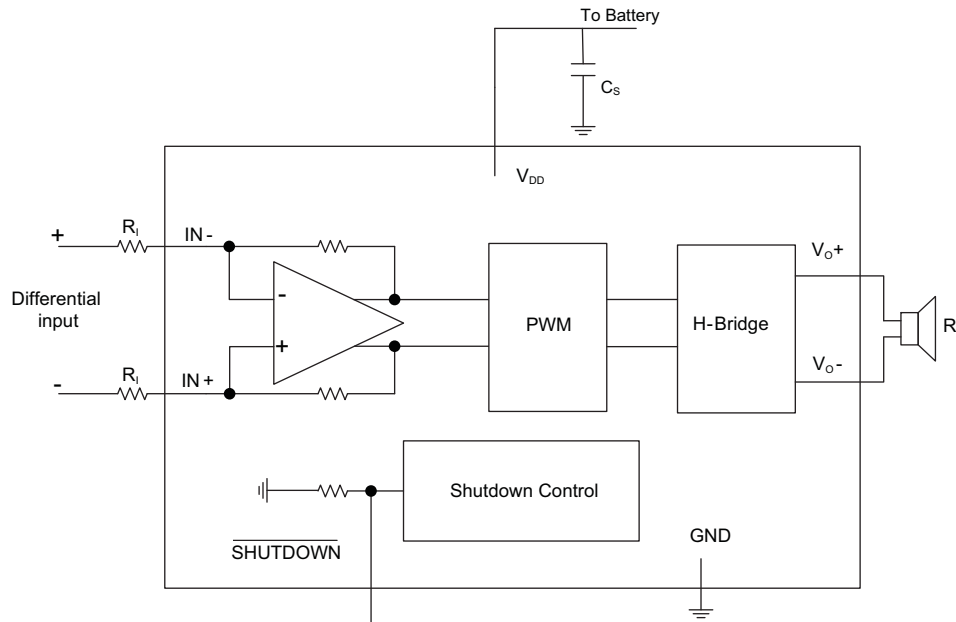

Figure 2: AAT5101 Application Schematic with DC-Coupled Fully Differential Input Configuration.

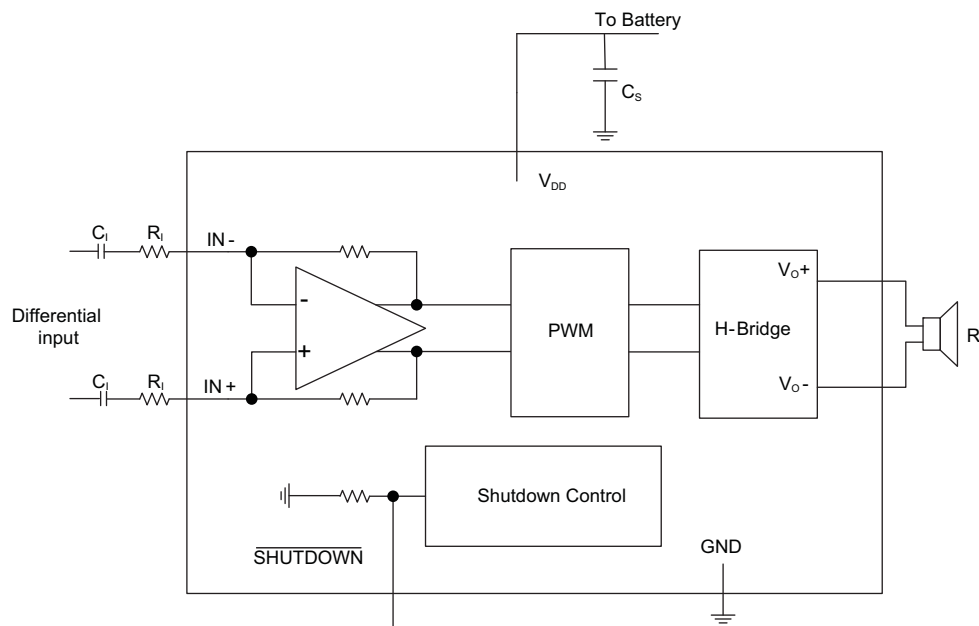

Figure 3: AAT5101 Application Schematic with AC-Coupled Fully Differential Input Configuration.

2.5W Mono Filter-Free Class D Audio Power Amplifier

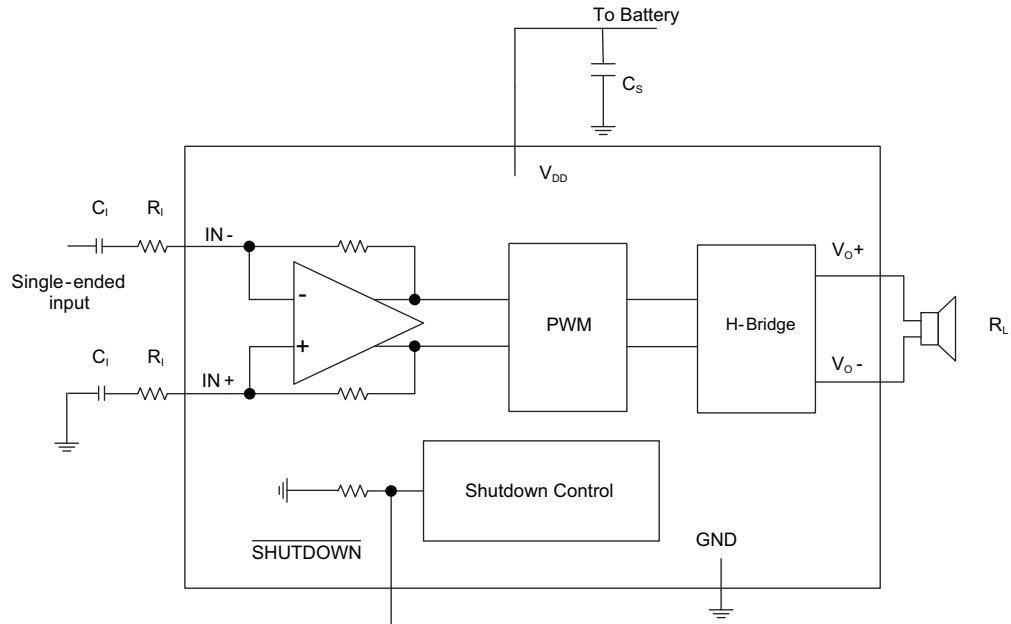

Figure 4: AAT5101 Application Schematic with Single-Ended Input Configuration.

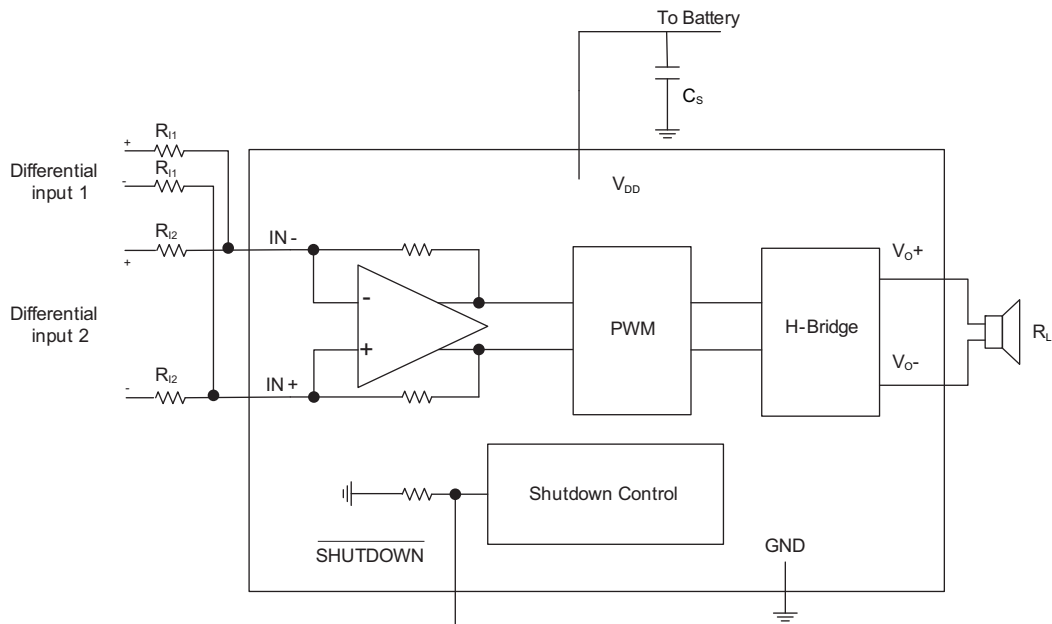

Figure 5: AAT5101 Application Schematic with AAT5101 Summing Two Differential Inputs.

2.5W Mono Filter-Free Class D Audio Power Amplifier

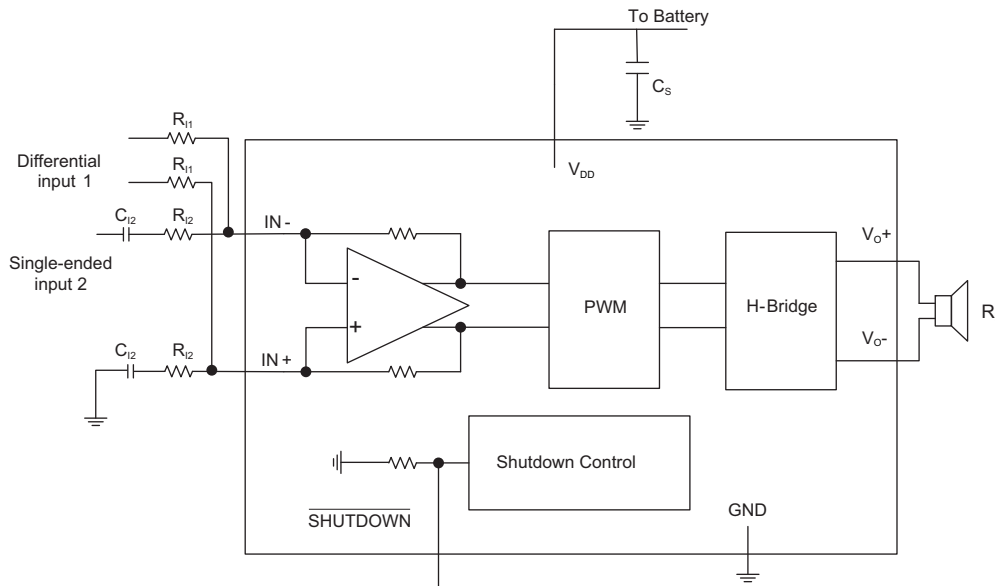

Figure 6: AAT5101 Application Schematic with AAT5101 Summing Differential Input and Single-Ended Input Signals.

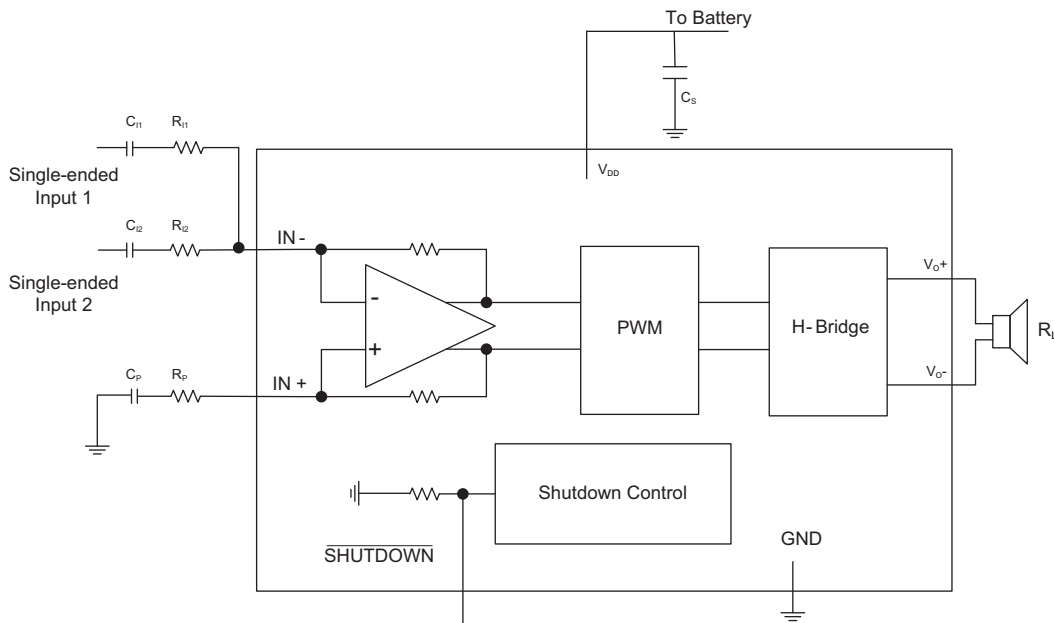

Figure 7: AAT5101 Application Schematic with AAT5101 Summing Two Single-Ended Inputs.

2.5W Mono Filter-Free Class D Audio Power Amplifier

PCB Guidance

The suggested PCB layout for the AAT5101 is shown in Figure 9. All components are placed as close as possible to the AAT5101's leads to achieve better performance.

The following guidelines should be used to help ensure a proper layout.

1. The decoupling capacitor (C4) should connect to the VDD pin and PVDD pin as closely as possible.
2. The input resistor (R1, R2) should be placed very close to the AAT5101.

3. The input routes should be similar and the distance between the two routes should be small.
4. The output traces should be short, wide, and not pass beneath the IC in the other layers.

WLCSP Package Light Sensitivity

The electrical performance of the WLCSP package can be adversely affected by exposing the device to certain light sources, such as direct sunlight or a halogen lamp whose wavelengths are red and infra-reds. However, fluorescent lighting has very little effect on the electrical performance of the WLCSP package.

Evaluation Board Information

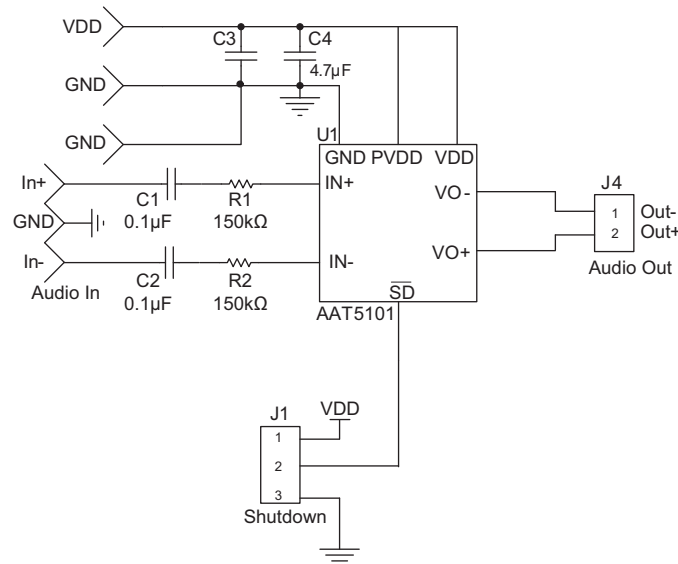
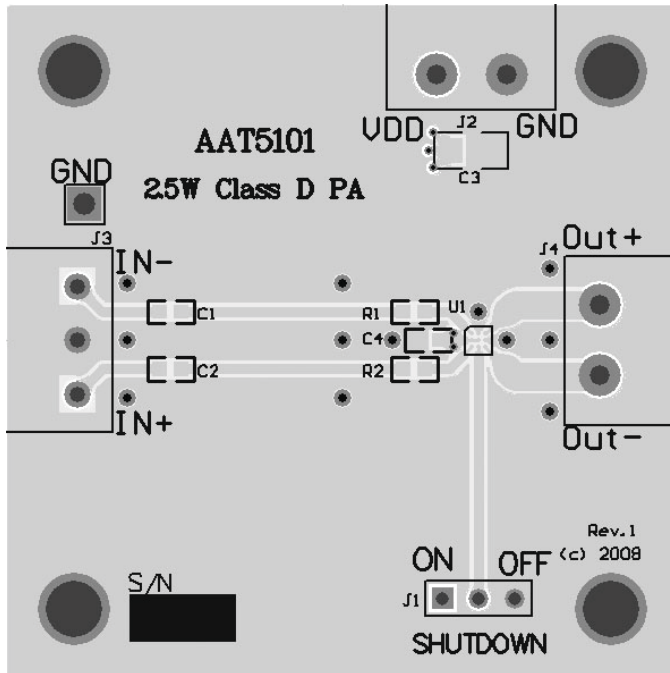

Figure 8: AAT5101 Evaluation Board Schematic.

Component Selection

Item	Part Description	Ref	PCB Footprint	Manufacturer	Part Number
1	SMD Resistor 150KΩ	R1, R2	0603	Vishay-Draloric	CRCW0603
2	Ceramic Capacitor 0.1µF, 50V, X7R	C1, C2	0603	TDK	C1608X7R1H104KT
3	Ceramic Capacitor 4.7µF, 6.3V, X5R	C4	0603	TDK	C1608X5R0J475MT
4	Not populated	C3			

2.5W Mono Filter-Free Class D Audio Power Amplifier



(a) Top Layer

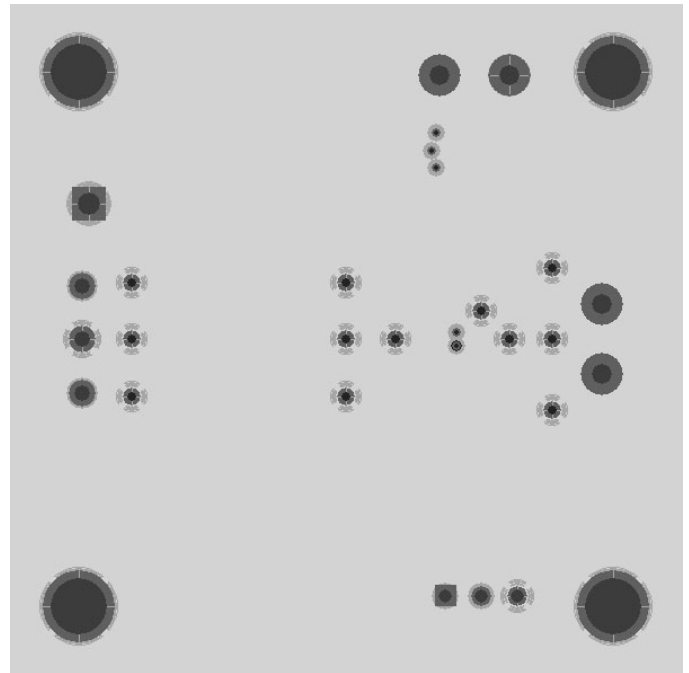

(b) Ground Plane

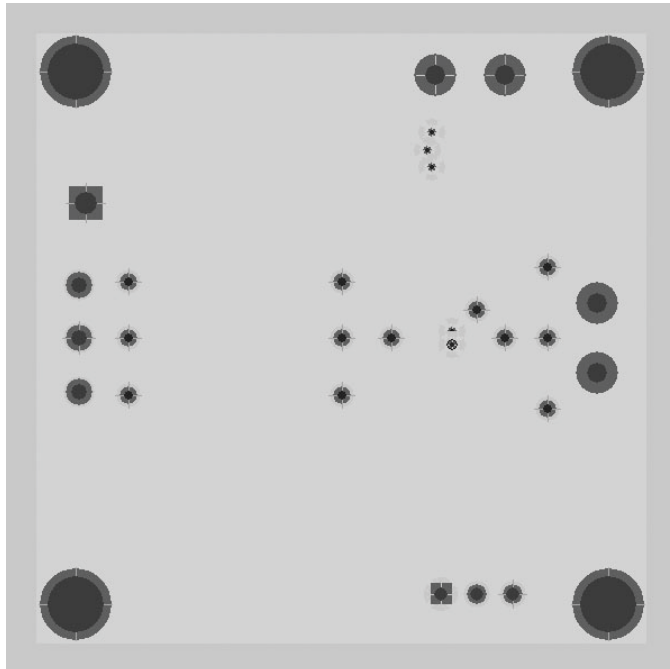

(c) Power Plane

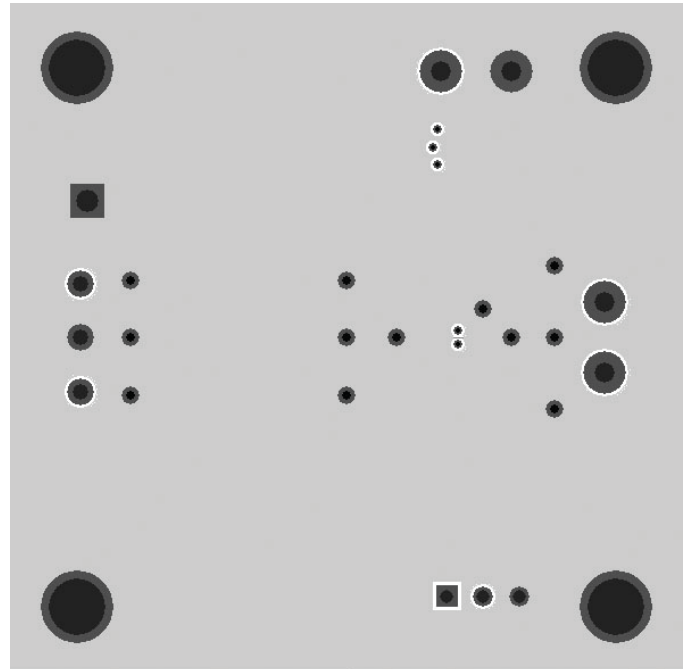

(d) Bottom Layer

Figure 9: AAT5101 Evaluation Board PCB Layout.

2.5W Mono Filter-Free Class D Audio Power Amplifier
Ordering Information

Package	Part Marking ¹	Part Number (Tape and Reel) ²
WLCSP-9	7HYW	AAT5101IUR-T1

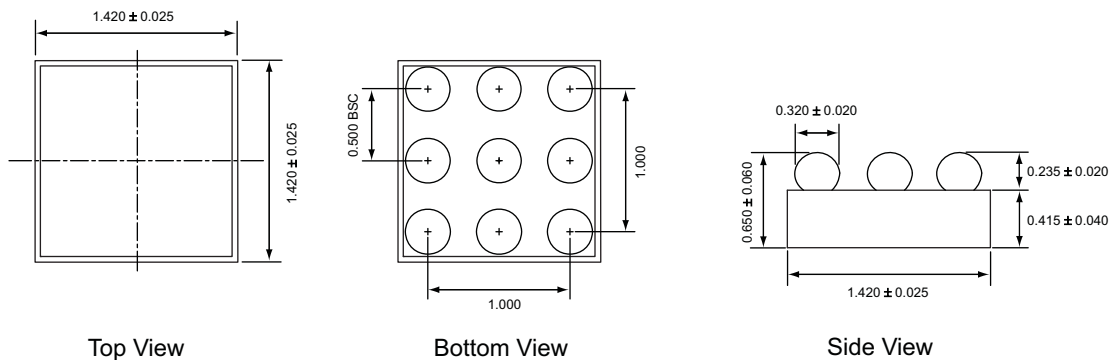

All AnalogicTech products are offered in Pb-free packaging. The term “Pb-free” means semiconductor products that are in compliance with current RoHS standards, including the requirement that lead not exceed 0.1% by weight in homogeneous materials. For more information, please visit our website at <http://www.analogictech.com/about/quality.aspx>.

Packaging Information
WLCSP-9

All dimensions in millimeters.

1. YW = date code.
2. Sample stock is generally held on part numbers listed in **BOLD**.

Advanced Analogic Technologies, Inc.
 3230 Scott Boulevard, Santa Clara, CA 95054
 Phone (408) 737-4600
 Fax (408) 737-4611



© Advanced Analogic Technologies, Inc. AnalogicTech cannot assume responsibility for use of any circuitry other than circuitry entirely embodied in an AnalogicTech product. No circuit patent licenses, copyrights, mask work rights, or other intellectual property rights are implied. AnalogicTech reserves the right to make changes to their products or specifications or to discontinue any product or service without notice. Except as provided in AnalogicTech's terms and conditions of sale, AnalogicTech assumes no liability whatsoever, and AnalogicTech disclaims any express or implied warranty relating to the sale and/or use of AnalogicTech products including liability or warranties relating to fitness for a particular purpose, merchantability, or infringement of any patent, copyright or other intellectual property right. In order to minimize risks associated with the customer's applications, adequate design and operating safeguards must be provided by the customer to minimize inherent or procedural hazards. Testing and other quality control techniques are utilized to the extent AnalogicTech deems necessary to support this warranty. Specific testing of all parameters of each device is not necessarily performed. AnalogicTech and the AnalogicTech logo are trademarks of Advanced Analogic Technologies Incorporated. All other brand and product names appearing in this document are registered trademarks or trademarks of their respective holders.