

Managing Portable Power Parameters for Dual USB / AC Adapter Charging

by

Phil Dewsbury

Product Line Director

Advanced Analogic Technologies, Inc.

With today’s proliferation of wireless and portable electronic equipment, a bewildering array of chargers and adapters are needed to keep a notebook PC, PDA, mobile phone, PMP, or MP3 player recharged. Not surprisingly, charging mobile accessories from the USB port of a notebook computer has become very popular. However, very different parameters apply when charging a lithium-ion or polymer battery from a USB port compared with an AC adapter, and these need careful management if a fast, safe, and successful charge is to take place under both methods. For example, AC adapter chargers have a much higher charging current and the high input-to-output voltage differential can sometimes cause the charging device to over-dissipate and shut down until the device has cooled, increasing the charging time. The USB port of a notebook or desktop computer (host) can source either 100mA or, after successful negotiation between host and the portable appliance (slave), 500mA of current. If however the current that is drawn begins to affect system performance, it will be reduced to the 100mA default value again.

Charger IC

The AAT3686 battery charger IC from AnalogicTech provides a highly integrated solution for successfully managing the charging of portable devices from both AC adapters and USB ports with the minimum of external components. Packaged in the space-saving TDFN 4x4mm package, the AAT3686, shown in Figure 1, includes all the necessary charging and protection circuits required to charge a Li-ion/polymer battery, while also integrating two separate, bi-directional charging paths.

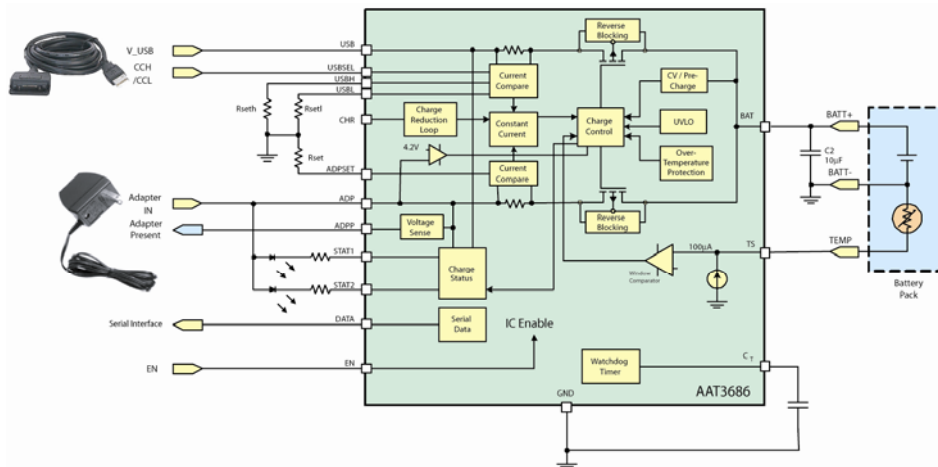

Figure 1: Application Circuit, AAT3686 Lithium-Ion/Polymer Linear Battery Charger.

The AAT3686 detects which power source is connected and turns on the necessary internal MOSFET. If both power sources are connected at the same time, the AC adapter charger will always be selected.

With either power source, the AAT3686 charges the battery in four separate stages, dependent upon the initial condition of the battery. A typical charging profile is shown in Figure 2. When fully discharged, the terminal voltage of a 4.2V Li-ion battery can be as low as 2.5V. On connection, the AAT3686 will check both the battery temperature and the charger voltage. If the battery voltage is below the pre-conditioning threshold, V_{MIN} , the charger will begin pre-conditioning the cell by trickle charging at 10% of the programmed current (Stage 1) to prevent excessive internal heating in the battery. Once the voltage exceeds V_{MIN} , the IC begins charging the battery in constant-current, fast charging mode (Stage 2). When the battery reaches its terminal voltage of 4.2V +/-1%, the charger switches from constant current to constant voltage mode (Stage 3).

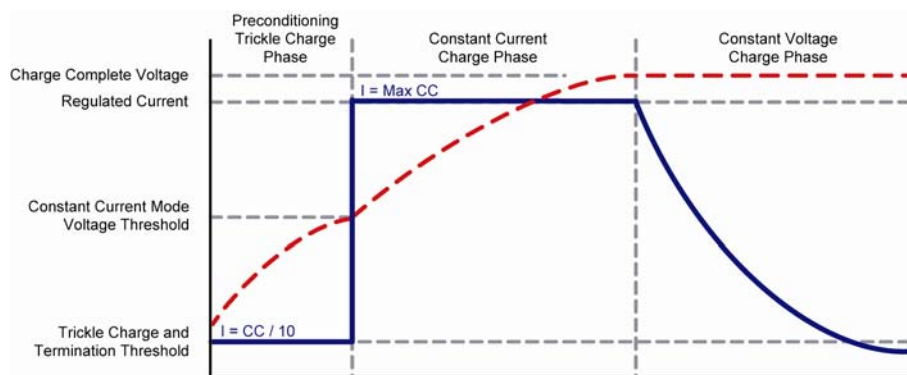

Figure 2: Typical Charging Profile.

As the battery approaches its maximum capacity, the charging current drops; when it has dropped to within 7.5% of the programmed charging current (35% for USB), the charger IC terminates charging and goes into a standby state (Stage 4), consuming only microamps of current, where it remains until the battery voltage falls below the recharge voltage threshold. An integral ‘watchdog’ timer in the AAT3686 is also able to terminate charging after a period of time that is preset by an external capacitor.

Thermal Loop

The IC includes a thermal loop to improve charging during periods of high dissipation. For example, with a charger adapter the maximum charging current can be set to 1.5A. If the output voltage is 5.5V, the IC would be required to dissipate 3W when the battery voltage was at 3.5V. Even at room temperature and with good thermal PCB layout, this would normally lead to a rapid rise in the charger die temperature and cause the device to turn off and cool down to protect itself. The device then turns on again and repeats the cycle.

The AAT3686, however, features a digital thermal loop that sets the charging current to the maximum level that will maintain a safe IC temperature, monitored by an internal temperature monitor. When the maximum temperature is reached, the charging current is immediately reduced to around 0.44 x

programmed current. The thermal loop re-evaluates the die temperature at 3s intervals, increasing the charging current in small increments either to the full charging current or until a temperature equilibrium is reached. This ensures that the battery is always charging with the maximum charging current regardless of the input voltage and ambient temperature, which significantly improves the charging time and system reliability.

USB Charging

The AAT3686 includes a USB Charge Reduction Loop to prevent the device from exceeding the power capability of the USB port. This loop monitors the USB line and automatically reduces the charging current should the supply integrity be threatened.

Over-voltage and over-temperature protection, and battery temperature monitoring are also included, along with two status outputs which can drive LEDs to give a visual indication of four charging events. A digital data reporting system can provide information on up to 22 different conditions of the charging system to a microcontroller via a single wire.

Conclusion

The AAT3686 is a versatile device that allows a single cell Li-ion/polymer battery to charge from either an AC adapter or, at a slower rate, from a USB port without exceeding protocol specifications or exceeding package thermal dissipation limits.