

Storing Power with Super Capacitors

By Thomas DeLurio, Senior Applications Engineering Manager
Advanced Analogic Technologies, Inc.

While portable system designers have sharply reduced the power requirements of their systems in active and standby mode over the last several years, a growing number of applications pose an entirely different problem. Some of the most attractive features in wireless and portable devices today demand high levels of current for very short durations. Often, this peak current exceeds the capabilities of the system power source. Ironically, just as advances in power management have allowed designers to reduce the footprint and cost of their systems by moving to smaller, lower cost Lithium-Ion batteries, they are finding users increasingly demanding applications that require higher levels of peak current than these new power sources can support.

This problem has emerged as designers have increasingly deployed higher current devices in portable systems despite their limited sourcing current. For example, a growing variety of wireless data cards for applications such as GSM, GPRS or WiMAX data communication use TDMA techniques which require a peak current during the transmission of signals which can exceed the maximum current specified in the PC card, CF Card and/or USB standards. Similarly, as designers have increased the resolution of camera phones to 2M pixel and beyond, they have also increased the amount of light required to achieve a high quality image. To reach these high levels, portable systems must drive flash LEDs at currents as high as 2A. Other applications such as GPS readings, music and video also exceed source current availability.

One way to solve this problem is to use a capacitor to store the current and deliver it quickly without draining the main battery. However, conventional capacitor capability would require either a very large case size or multiple devices connected in parallel. A more practical solution for space-constrained portable systems is to use very high value or so-called "super" capacitors. These devices offer high levels of capacitance in a relatively small case size. Working with the battery and a DC/DC converter, a super capacitor discharges its power during peak loads and recharges between peaks, providing the power needed to operate systems from battery operated hosts.

By using a super capacitor, designers can deliver the high current levels needed for these short duration events and then recharge from the battery between events. By reducing the current drawn from the battery, this architecture offers users improved talk time and longer battery life. It also allows the designer to reduce the system footprint by optimally sizing the battery and power circuitry to cover just the average power consumption instead of peak levels.

The challenge for designers is determining how to most efficiently interconnect the battery, DC/DC converter and super capacitor in a way that will limit the super capacitor charge current and continually recharge the capacitor between load events. This paper will identify some of the challenges of storing power with super capacitors, identify some of the issues designers must overcome, explore two techniques for delivering high currents without overloading the host supply, and then illustrate potential solutions using implementations of sample applications with test results from a real system.

Defining a super capacitor

What is a super capacitor? Like any capacitor, a super capacitor is basically two parallel conducting plates separated by an insulating material known as a dielectric. The value of the capacitor is directly proportional to the area of the plates and inversely proportional to the thickness of the dielectric. Manufacturers building "super" capacitors achieve higher levels of capacitance while minimizing size by using a porous carbon material for the plates to maximize the surface area and a molecularly thin electrolyte as the dielectric to minimize the distance between the plates. Using this approach they can manufacture capacitors with values from 16mF up to 2.3F. The construction of these devices results in a very low internal resistance allowing them to deliver high peak current pulses with minimal droop in the output voltage.

These super capacitors reduce system footprint requirements by delivering a very high capacitance in a relatively small case size. They can be manufactured in any size and shape and recharge in seconds. By averaging out high power demands, they extend battery life by up to a factor of five and allow designers to specify much smaller, lighter and less expensive batteries. They also offer a very low ESR (Equivalent Series Resistance).

Inherent challenges

That low ESR presents designers with an inherent problem during the charge cycle, however. In any system the capacitor is initially discharged. When the supply voltage is then applied, the super capacitor looks like a low value resistor. This can result in a huge in-rush current if the current is not controlled or limited. Therefore, designers must implement some sort of in-rush current limit to ensure the battery does not shut down. Typically any circuit of this type also requires short-circuit, over-voltage and current flow protection.

One simple strategy is to use a series resistor. In a typical PC Card circuit the maximum current that can be drawn prior to successful host/card negotiation is 70mA. If we assume that the PC Card controller needs half that current to perform the negotiation, then at power-up the super capacitor must be either disconnected from the supply or current-limited using an approximately 100Ω resistor ($R=V/I$). Given those factors, the capacitor will be fully charged in approximately 6.7 minutes (assuming the capacitor is fully charged in approximately 5 time constants).

A more practical approach would allow the PC Card to source more power after the successful negotiation between the host and the card. A lower value resistor can then be used to increase the charging current. As the capacitor starts to charge and the voltage starts to rise, the power dissipation declines and the resistor value can be decreased. The diagram below depicts a sample circuit comprised of a series of decreasing resistor values being switched during the capacitor charging cycle. This architecture requires that the timing of the switching points be closely controlled, which would demand very accurate and expensive resistors, or monitored by several additional voltage detectors. Furthermore, when the capacitor is fully charged and the PC card is removed, the energy stored in the capacitor would be sufficient to damage the connector pin.

Simple charging scheme

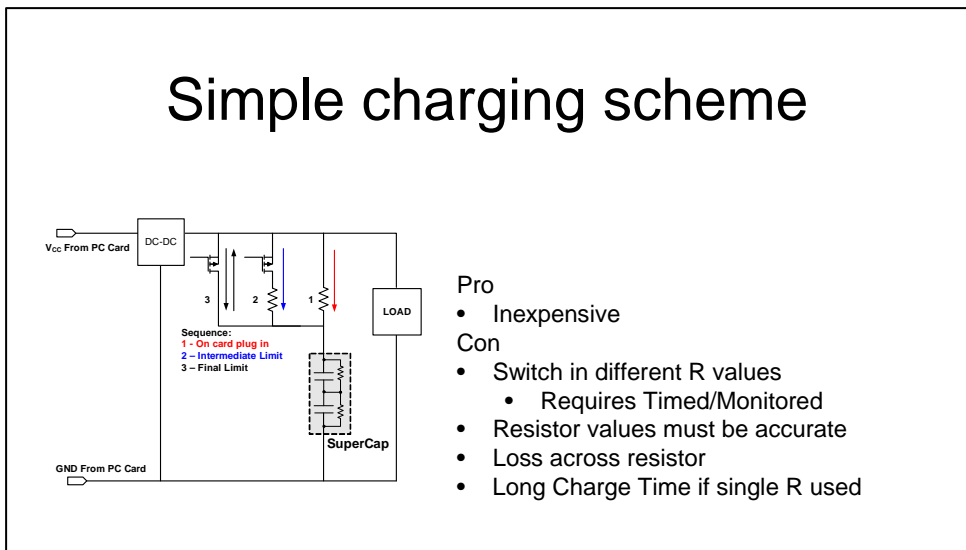

- Pro
- Inexpensive
- Con
- Switch in different R values
 - Requires Timed/Monitored
 - Resistor values must be accurate
 - Loss across resistor
 - Long Charge Time if single R used

Figure 1: Simple Charging Scheme

A third approach is to use a current-limiting SmartSwitch™ to charge the super capacitor. This type of device uses an independent integrated P or N channel MOSFET as a load switch and integrates additional monitoring and protection circuitry to limit the amount of output current. Products of this type feature thermal over-load protection to ensure that the device will turn off if the chip temperature exceeds its rated maximum while in current limit. As the chip cools down, the device will turn back on and thermally oscillate at a low frequency until the period of high dissipation ends. These devices typically feature an independent current limit to avoid violating standards or draining the battery. They also feature reverse blocking to keep the super capacitor charge from going back to the source and to protect the source during a short circuit. They offer a power loop to control the charge rate and low RDSon to eliminate thermal foldback or droop in the output voltage. Moreover, these devices only require 1.4V for the enable control pin to set startup and full power current.

Current Limiting Smart Switch

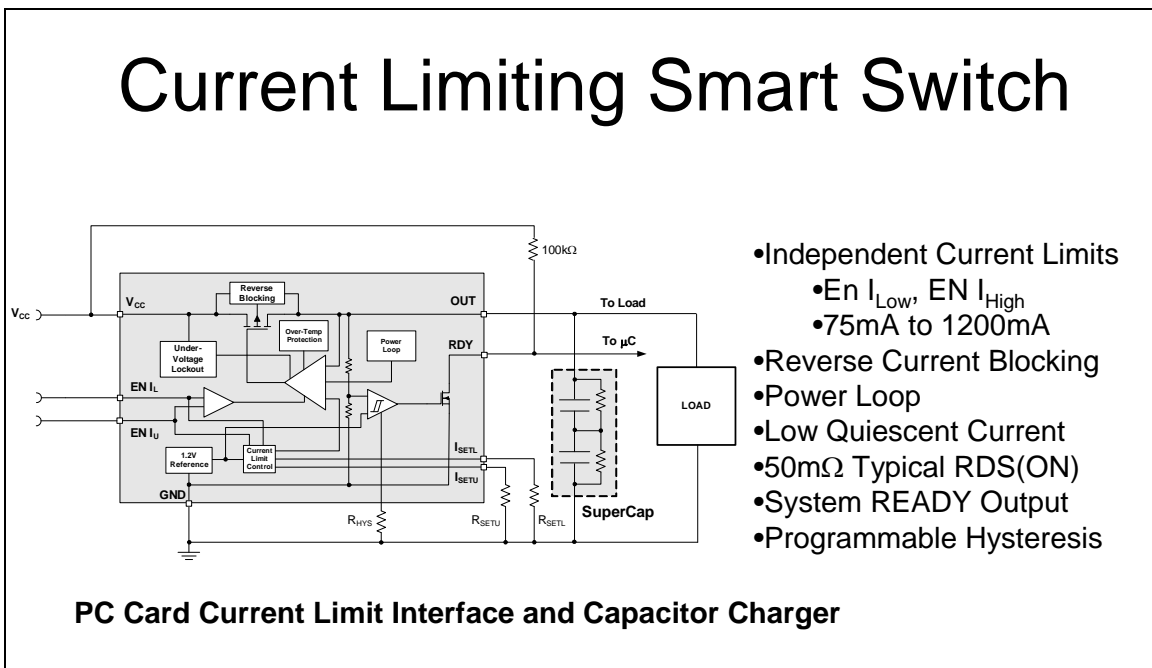

- Independent Current Limits
 - $EN I_{Low}$, $EN I_{High}$
 - 75mA to 1200mA
- Reverse Current Blocking
- Power Loop
- Low Quiescent Current
- 50mΩ Typical RDS(ON)
- System READY Output
- Programmable Hysteresis

PC Card Current Limit Interface and Capacitor Charger

Figure 2: Current Limiting SmartSwitch™

In a typical super capacitor application, the SmartSwitch™ turns on and immediately limits current due to the high in-rush current. This large in-rush current drives up temperature and

drives the device into thermal shutdown where it thermally oscillates. All SmartSwitch™ devices are designed to operate in this manner. However, during the time the switch is off, the capacitor is not charging, and therefore increasing the time to full charge. Moreover, there is no way to detect when the capacitor is fully charged and ready for transmission without additional circuitry.

A current-limited SmartSwitch™ adds all the circuitry needed to limit current, protect the PC card connector, continuously charge the capacitor, notify the system when it is ready for use and determine when to start recharging the capacitor.

Devices such as AnalogicTech's AAT4620/1 SmartSwitch™ feature two different current limits for host/card negotiation. On power up the devices provides a low resistance path between the supply and the super capacitor. If thermal dissipation is low, the device eventually enters current limit and the capacitor continues to charge until it reaches approximately 98% of its final value. At that point a system ready signal changes state alerting the system that transmission can begin. If thermal dissipation is high, the chip temperature will rise rapidly. When it reaches an internally programmed limit, the device initiates an integrated digital power loop which reduces the current to a safe value. The power loop regulates the die's temperature to approximately 100°C by sensing the die temperature at regular intervals and increasing or decreasing the current by 1/32 of the current limit set point. This function protects the device while minimizing charge time by ensuring that the super capacitor is charging at all times.

Typically designers size the super capacitor to minimize the voltage droop during transmission and allow recharging during the receive phase. The AAT4620/1 adds adjustable hysteresis for a Ready (RDYB) signal. The RHYS resistor sets the hysteresis in which the RDYB signal is turned back off. The RDYB signal always turns on when $V_{OUT} = 0.98 \times V_{IN}$. The AAT4620 stops charging the supercap when $V_{OUT} > (V_{IN} - 18\text{mV})$. It then turns back on when $V_{OUT} < (V_{IN} - 18\text{mV} - \text{hysteresis})$.

Sample Applications

To demonstrate the advantages of this approach, we first applied this circuit to a wireless data card design. GPRS data cards typically must supply relatively large amounts of current to the power amplifier (PA) for short duration to send data. In this particular example the GPRS card used one slot @ +33 dBm. Current draw from the super capacitor was 1.1A for 577µsec/4.615msec or 12.5% duty cycle. PA power consumption was equivalent to +33 dBm (50% efficiency) or 2W/50% or 4W. Current during transmit was 4W/3.75V or 1.1A. Average current was 1.1A X 12.5% of the duty cycle or 138mA. A second 2-slot example drew 1.1A from the super capacitor for 1.154 msec every 4.615msec. At 2 slots per frame this represented 25% of the duty cycle. PA power consumption and current during transmit was the same. Average current was 1.1A x 25% or 275mA.

Wireless data card Application

Boost Converter plus Smart Switch

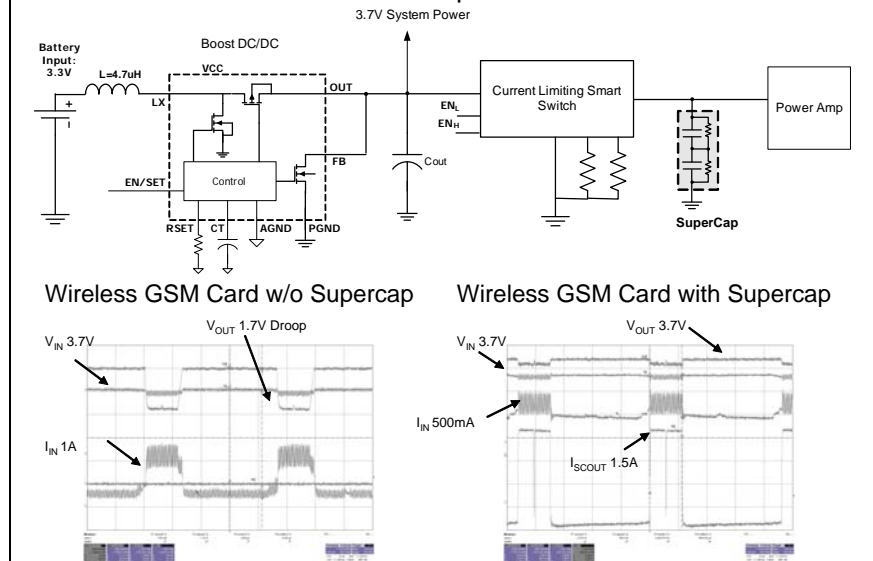

Figure 3: Wireless Data Card Application

In this demonstration, the battery supplies input to the boost converter which supplies a constant system supply of 3.7V. The super capacitor supplies approximately 1.5A of peak current during GPRS 2-slot data transmission and the SmartSwitch™ recharges the super capacitor during receive function. The two waveforms compare a GSM PC Card without a super capacitor load (left) with a GSM PC Card with a super capacitor load (right). Together they illustrate how by designs using a SmartSwitch™ to charge the super capacitor can eliminate droop during transmit.

In a second example, we used a current limiting SmartSwitch™, Boost DC/DC LED driver and super capacitor in a high current flash LED application (see figure 4). The SmartSwitch™ is integrated with the Boost DC/DC LED Driver as shown. Many of today's camera phones now offer resolution of 2 Mpixel and above. These higher levels of image resolution require proportionally higher levels of light to achieve a high quality image. To achieve these light levels, flash LEDs must be driven at currents of between 1A and 2A. Complicating the problem, the forward voltage across the LED as these high currents can range up to 4.8V. If we include 200 mV of overhead for the current control circuitry, it's easy to see how the total load voltage during a flash event can range up to 5V.

High current Flash LED application for camera or cell phone

Smart Switch plus Boost Converter - Supercap provides the Flash Current

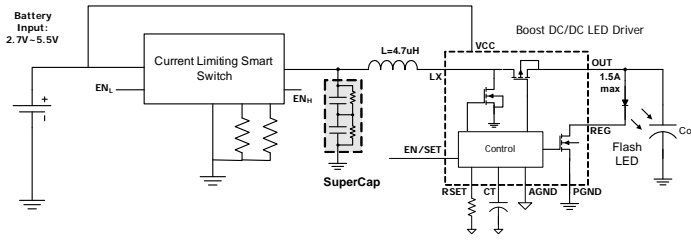

Smart Switch integrated with the Boost Converter

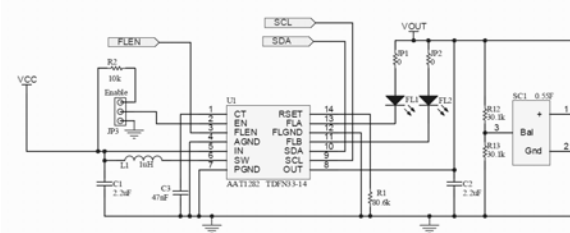
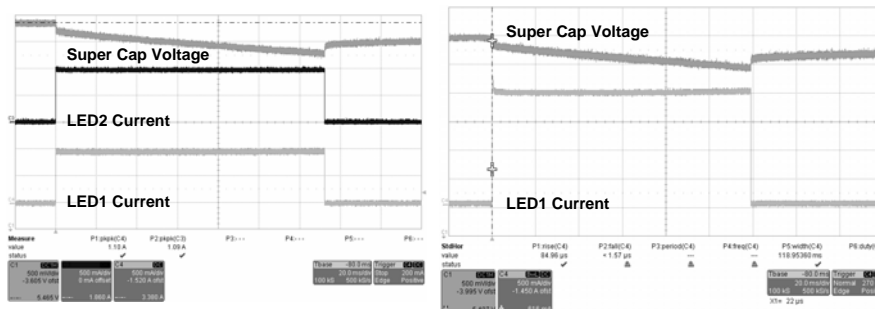

Figure 4: Flash LED Application

To achieve these levels of power, designers must use a boost converter. If the battery voltage is 3.5-V and the boost converter is 90% efficient, the battery must supply over 3A for the duration of a 2A flash pulse. Typically this requirement will result in the battery protection circuit shutting the battery down or create a low voltage shutdown with significant amounts of energy left in the battery.

Figure 5 shows test results using two flash LEDs at 1A each and 1 LED at 2A. As can be seen, the supercap can easily supply the necessary current for 100ms while holding up the supply voltage sufficiently above the V_f of the LED. Between flash events, the supercap is recharged at a slower rate to be ready for the next picture. The time to charge the supercap between flashed is set externally and can be optimized for different battery sizes/chemistries.

Two LED's powered at 1A each and One LED powered at 2A



- $V_{in} = 3.62V$ (875mA/hr Li-Ion Polymer battery cell)
- Flash Time-out set for 100ms
- LEDs = Lumiled PWM-4
- Super Cap = Cap-XX, HS206F - 0.55F - 85mΩ ESR
- $V_{in} = 3.62V$ (875mA/hr Li-Ion Polymer battery cell)
- Flash Time-out set for 100ms
- LED = Lumiled PWM-4
- Super Cap = Cap-XX, HS206F - 0.55F - 85mΩ ESR

Figure 5: Flash LED Application Test Results

Conclusion

Until recently super capacitors have been rarely used in portable systems. Typically they have been limited to back-up or standby functions that use relatively low currents and offer fairly long charge times. But a new generation of SmartSwitch™ devices which integrate all the functions needed to limit current, protect the PC card connector, continuously charge the capacitor and notify the system when the capacitor is ready for use are changing that scenario. By combining these new smart switches with super capacitors, designers can now create compact solutions which supply high levels of current for short durations and, in the process, extend battery life or allow the use of smaller, lighter and less expensive power sources.

References:

Comparison of xenon flash and high current LEDs for photo flash in camera phones
Use of Supercapacitors to Improve Performance of GPRS Mobile Stations
Pierre Mars, CAP-XX Ltd

© Advanced Analogic Technologies, Inc. (November 2007)

AnalogicTech and the AnalogicTech logo are trademarks of Advanced Analogic Technologies Incorporated. All other brand and product names appearing in this document are registered trademarks or trademarks of their respective holders.