

Highest Efficiency 16 Series LED Backlight from a Single Cell Battery

By Steve Hawley, Senior Applications Engineering Manager,
Advanced Analogic Technologies, Inc.

Traditionally, systems designers have employed CCFLs to provide backlight for large format LCD displays in notebook computers, computer monitors, portable media players and other portable consumer electronic products. The availability of new, high intensity LEDs allows designers to consider LED backlighting for large format displays. When compared to CCFL, LED backlight offers designers the benefits of higher operating efficiency, reduced part count, excellent life expectancy, expanded dimming capability and an improved color gamut. The increased operating efficiency results in less heat and increased battery life – which is highly desirable in handheld systems.

LED backlights have been used extensively in small and medium size portable LCD displays – generally less than 3 inches. In many cases, these applications require two to six white LEDs (WLEDs) in parallel. The parallel arrangement allows the control IC to utilize inexpensive low voltage CMOS processes (see Figure 1).

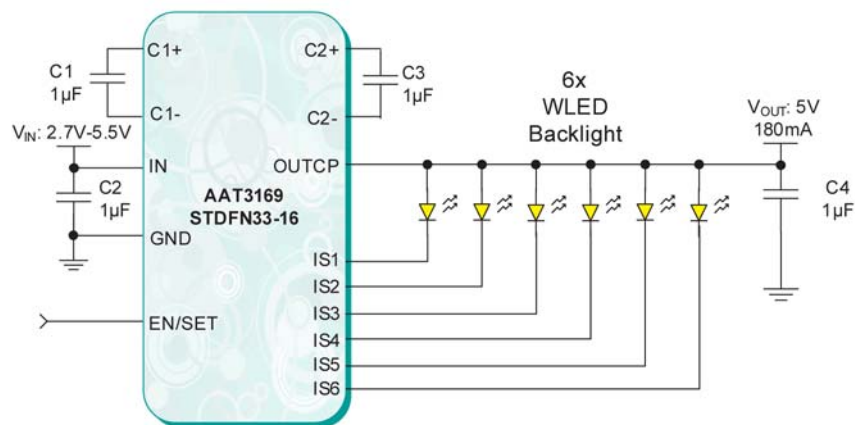

Figure 1: Six Parallel WLED Backlight
(Problem: Non-Ideal Current Matching)

The IC drives the LEDs with a constant current programmed by a low-side current sink (high side current source also are available). However, the resulting channel-to-channel mismatch is unacceptable in large format LCD displays, where a greater number of LEDs are required across a larger viewing area.

To address this shortcoming, systems developers are turning to LEDs connected in series to perform the backlight function for large format portable LCD displays. The series arrangement guarantees LED current matching and uniform brightness across the LCD surface. However, the LED string requires a high output voltage to drive the series WLED string. The high output voltage must be derived from a single cell Li-ion battery pack; with an input voltage as low as 3.2V. This high differential voltage places demands on the traditional step-up (boost) LED driver solution (Figure 2).

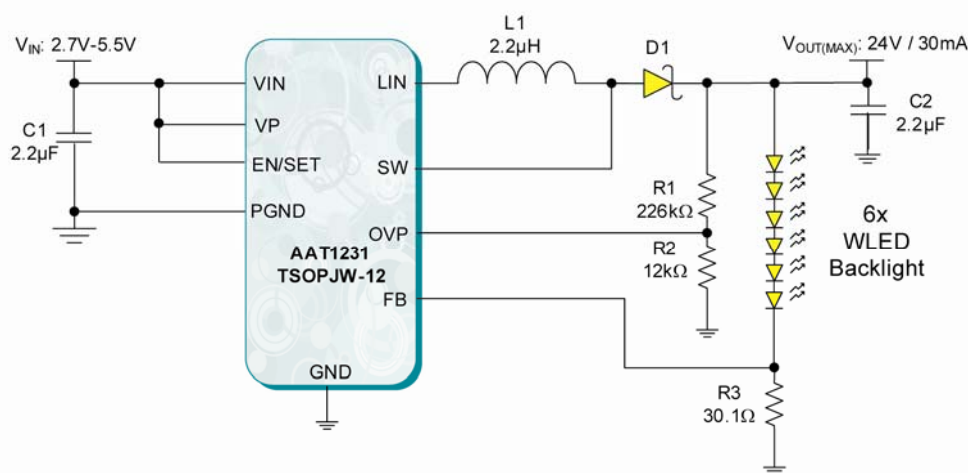

Figure 2: Six Series WLED Backlight
(Problem: Limited Number of Series WLEDs)

The following discussion will focus on a coupled inductor boost approach for constant current WLED backlight drivers. This approach is also applicable to constant-current multi-string (R-G-B) backlight applications as well as constant output voltage applications (OLED).

Design Issues with Large Format Boost LED Drivers

For example, a typical 7 inch TFT LCD screen for a portable DVD player requires up to 16 WLEDs. For uniform illumination, series connected LEDs are preferred. At low input voltage (V_{IN}), traditional boost converters must operate at a high duty-cycle (D) to generate the output voltage (V_{OUT}) necessary for conduction of the series LED string. For a continuous mode boost converter, D is defined by the following equation:

$$D = \frac{V_{OUT} - V_{IN}}{V_{OUT}}$$

At high V_{OUT} , the duty cycle (D) approaches one which translates to a short OFF-time ($1 - D$) and high RMS current (I_{RMS}) in the output circuit – when diode $D1$ is conducting. Worst-case I_{RMS} can be estimated with the following equation:

$$I_{RMS} = I_{OUT} \times \sqrt{\frac{4 \times D}{3 \times (1 - D)^2}}$$

The power loss during off time ($P_{LOSS(OFF)}$) is proportional to I_{RMS} squared multiplied by the parasitic resistance in the output circuit. Parasitic resistance is found in the inductor wire, circuit traces, output capacitor equivalent series resistance (ESR) and output rectifier ($D1$).

$$P_{LOSS(OFF)} = I_{RMS}^2 \times (R_{WIRE_TRACE} + R_{ESR} + R_{D1})$$

During the OFF-time ($D1$ conducting), the boost switch (SW) voltage is greater than the output voltage by a diode drop. With 16 series WLEDs, SW voltage can be as high as 65V. This requires a high-voltage boost switch. For a given IC technology, high voltage switching devices are less efficient and more costly than low voltage devices.

For example, with a 3.2V input battery voltage and 55V output voltage; the IC control circuit must be capable of at least 94% duty-cycle. Traditional boost IC controllers have a

maximum duty-cycle from 85-95%. These factors limit the effectiveness of the traditional boost topology for large numbers of series WLEDs.

Additional Inductor Winding Simplifies Control and Improves Efficiency

To reduce size and cost, portable equipment manufacturers are seeking to integrate various LED lighting functions into the same driver IC. In addition to backlight, these functions include RGB indicators, keypad illumination, and flash / movie-mode to support camera and video features.

Unfortunately, the traditional boost driver is not effective at driving dissimilar LED strings. Consider the case of an integrated six WLED and two Flash LED (FLED) driver, as shown in Figure 3. The output voltage required by the WLED string is much higher than the output voltage required for the FLED string.

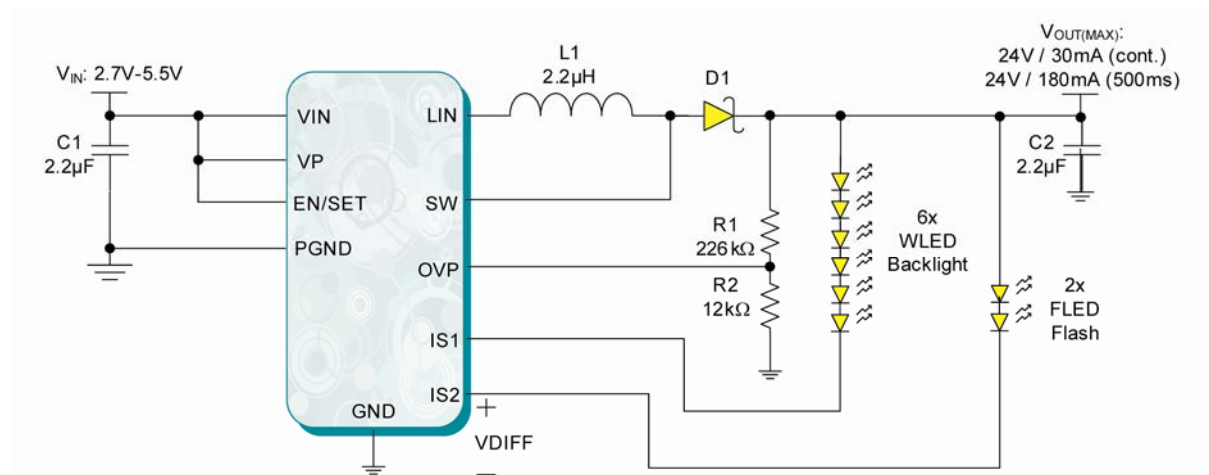

Figure 3: Six Series WLED Backlight plus Two Parallel FLED
(Problem: Low Efficiency during Flash Event)

During simultaneous backlight and Flash/Movie-mode events, the positive voltage mismatch is applied across the Flash current sink (pin IS2) to ground – resulting in high differential voltage (V_{DIFF}) which can result in significant losses in the current sink. In addition, the current sink must be rated for high voltage, increasing the IC size and cost.

To solve this problem, the circuit shown in Figure 4 uses a coupled inductor and the AAT1231 LED driver from Analogic Technologies for large format LED backlight applications. The improved boost circuit provides 55V output at 20mA for 1.2W continuous output power to drive 16 series WLEDs – derived from a single cell Li-ion battery. All that is required is an additional winding in series with the main inductor winding.

The coupled inductor approach reduces the operating duty cycle (D) and increases the available output voltage range of the standard boost topology. The reduced D contributes to higher operating efficiency and reduced component stress.

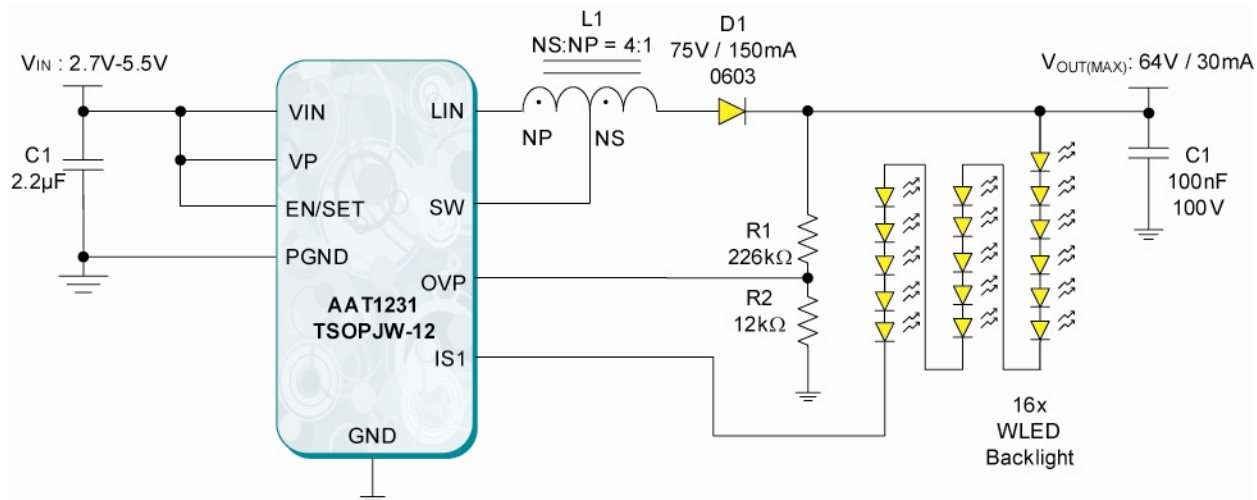

Figure 4: Sixteen Series WLED Backlight Coupled-Inductor
(Solution: Increased Series WLEDs – Ideal Current Matching)

Energy is stored in the inductor's primary windings during the ON-period. However, unlike the traditional boost driver, the secondary turns (NS) provide increased effective inductance during the OFF-period – reducing the current slew rate and resulting RMS current in the output circuit. The duty cycle (D) and the switch voltage (SW) are reduced by an amount determined by the turns ratio (NS/NP); which is the ratio of the inductor's secondary turns to primary turns. This yields higher operating efficiency than the traditional boost circuit.

The output rectifier must be rated to withstand the output voltage plus the negative voltage appearing on the secondary winding during the ON-period. A high voltage, low leakage ultra-fast rectifier was selected (D1). The rectifier is rated at 80V and is available in a small 0603 package.

The coupled inductor is the CTX01-17851-R from Cooper Technologies providing primary inductance of 2.2µH, turns ratio of 4:1 and saturation current of 2.0A in a small 5x5x1.2mm package. The reduced winding density of the coupled inductor yields a slightly larger inductor size than a similarly rated non-coupled boost inductor.

The turns ratio (NP/NS) is selected to maintain the drain voltage below the switch rating:

$$V_{DRAIN(ABS-MAX)} \leq V_{IN} + \left[(V_{OUT} - V_{IN}) \times \frac{NP}{NP + NS} \right] + V_S$$

The designer must specify a coupled inductor with low leakage inductance. This minimizes the drain voltage spike (V_S) which occurs during the turn-OFF event; when the leakage energy rings with the parasitic capacitance.

The duty cycle is reduced by an amount determined by the coupled inductor turns ratio, NS/NP:

$$D = \frac{V_{OUT} - V_{IN}}{V_{IN} \times \left(\frac{NS}{NP} \right) + V_{OUT}}$$

The coupled inductor yields efficiency up to 84%. The low cost TSOPJW-12 package requires no additional heat sinking.

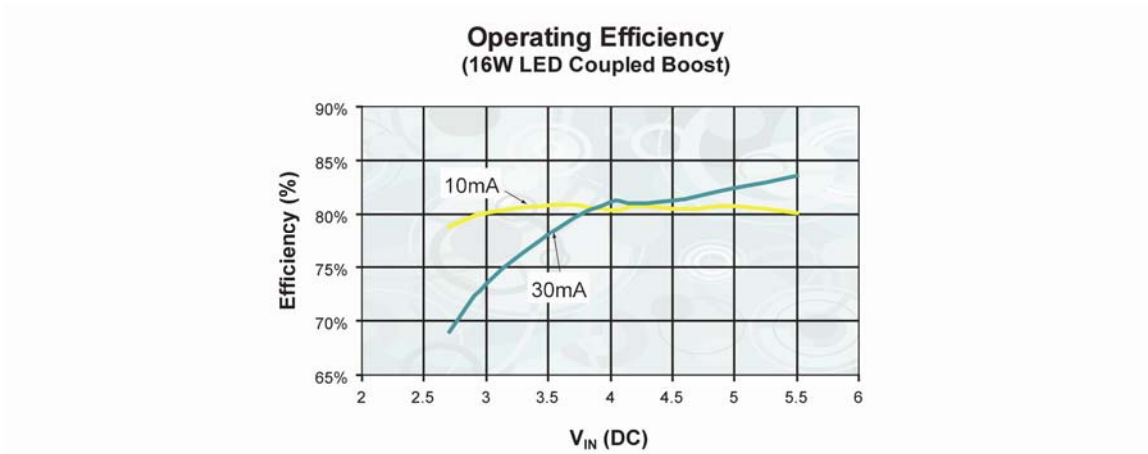

Figure 5: Efficiency Vs. Input Voltage
Coupled Inductor Boost Driving Sixteen Series WLEDs

The coupled boost topology provides additional advantages for integrated lighting applications. Unlike the traditional boost topology, the designer may set the voltage in the individual LED strings by adjusting the turns ratio; reducing the power loss and eliminating the high voltage current sink requirement, as shown in Figure 6.

The circuit provides continuous drive to 16 WLED (OSRAM PLZ22) and non-continuous drive to 2 FLEDs (Sharp GM5BW05340) at 150mA for 500ms. Continuous FLED operation at 50mA satisfies Movie/Torch mode operation.

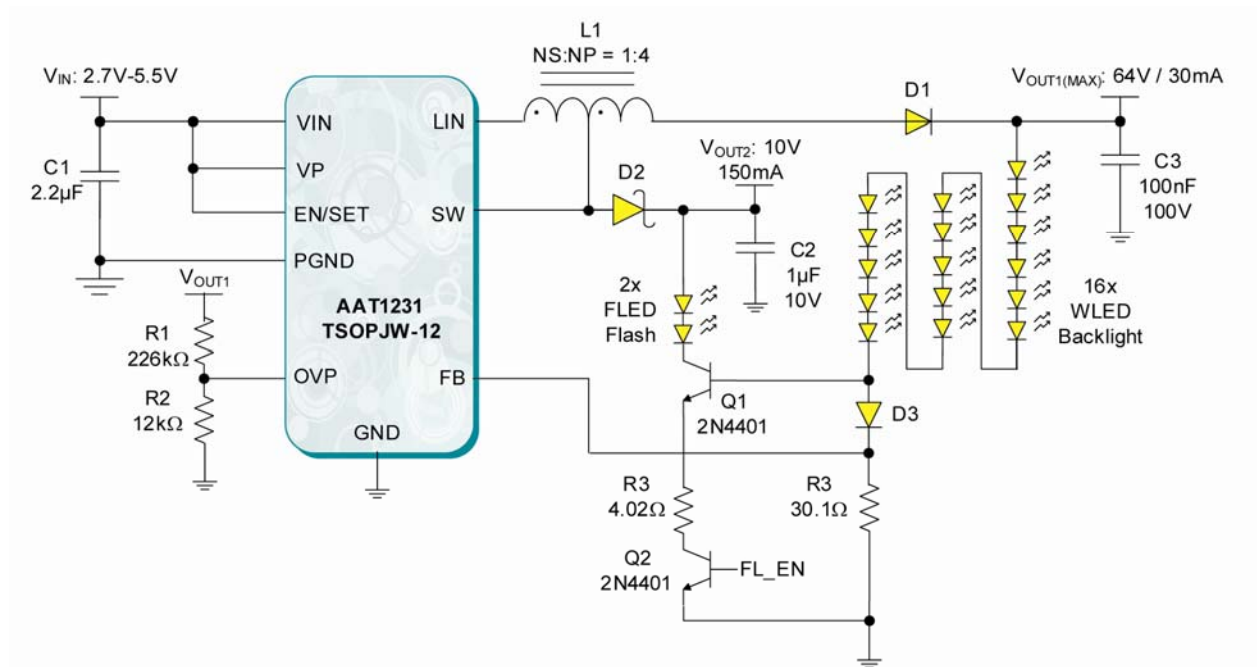

Figure 6: Sixteen Series WLED Backlight plus Parallel Two FLED Coupled-Inductor
(Solution: Ideal Current Matching and High Flash Efficiency)

A current mirror consisting of transistor Q1 and diode D3 were added to regulate the FLED current at 150mA; independent of the WLED current. Diode D2 and output capacitor C2 are sized by the FLED load. Transistor Q2 toggles the Flash without degrading the WLED current. As an added benefit, output capacitor C2 clamps the leakage inductance voltage spike; providing additional operating voltage margin at the AAT1231's switching pin.

The coupled inductor allows the design to operate each LED string and current sink at the optimum LED string voltage - achieving a higher operating efficiency and while reducing system cost. This multiple-output coupled inductor topology is highly scalable. Additional windings may be added for constant current (LED) or constant voltage (OLED, etc.) loads.