

## USB Port or AC Adapter Lithium-Ion/Polymer Battery Charger: The Power of Simplicity

By Alan Elbanhawy, Director, Advanced Power Systems Designs  
Advanced Analogic Technologies, Inc.

### Abstract:

The myriad of portable applications with an embedded single cell Li-ion/polymer battery require a full-featured and robust battery charger which offers good functionality, very small size, great price/performance value, and flexibility of the power source. The AAT3681A offers all of the above with the simplicity of minimal external components.

When coupled with a very small outline of 2.0mm x 2.1mm the device makes a great fit for portable and ultra portable appliances. This device is the closest a designer can get to a plug-and-play charger that saves on design and PCB layout times and helps with quick time-to-market efforts.

### Introduction:

Analogic Tech offers a very large portfolio of power conversion solutions specifically designed for the portable and hand held battery operated electronic appliances. One of the most important aspects of a successful design is how perfect the fit of the device is to the intended application. In the case of the AAT3681A, the functionality of modern portable appliances is expanding at an amazing pace where new features of all sorts are being added to satisfy the market's needs. Hence, the intent of offering this device is to package all the functionality required for a single cell Li-ion battery charger while requiring minimum design effort from the circuit designer who now can concentrate on the general aspects of the design rather than the very involved details of the battery charger's design.

The AAT3681A Battery Manager is an integrated single cell lithium-ion/polymer battery charger IC, designed to operate from a DC power source or USB port up to an input voltage of 7.5V. It requires just one external component for full functionality. The AAT3681A precisely regulates battery charge voltage and current for 4.2V (4.375V option) lithium-ion/polymer battery cells. When charged from an AC adapter or USB port, the battery charging current can be set by an external resistor up to 300mA. Battery charge state is continuously monitored for fault conditions. In the event of an over-voltage, short-circuit, or over-temperature failure, the device will automatically shut down, thus protecting the charging device, control system, and battery under charge. A status monitor output pin is provided to indicate the battery charge status by directly driving an external LED.

The AAT3681A is available in a Pb-free, thermally enhanced, space-saving 8-pin 2.0x2.1mm SC70JW package and is specified for operation over the -40°C to +85°C temperature range.

The newly released AAT3681A is a single cell battery charger for a large variety of applications such as:

- Bluetooth® Headsets
- DECT Headsets
- Digital Still Cameras
- MP3, Portable Music, and Portable Media Players
- Wrist Watches
- Other Lithium-Ion/Polymer Battery-Powered Devices

Though the device was designed for simplicity and ease of immediate design, it packs a high number of features to help optimize both the battery charging performance and PCB layout real estate. The following are some of these features and functions

- USB or AC Adapter System Power Charger
- Programmable from 15mA to 300mA
- 4.0V ~ 7.5V Input Voltage Range
- High Level of Integration with Internal: Charging Device
- Reverse Blocking Diode
- Automatic Current Sensing
- Automatic Recharge Sequencing
- Full Battery Charge Auto Turn Off/Sleep Mode/Charge Termination
- Shutdown Current <1 $\mu$ A
- Automatic Trickle Charge for Battery Pre-Conditioning Over-Voltage and Emergency Thermal Protection
- Power On Reset and Soft Start
- LED Status Pin
- 8-Pin 2.0x2.1mm SC70JW Package

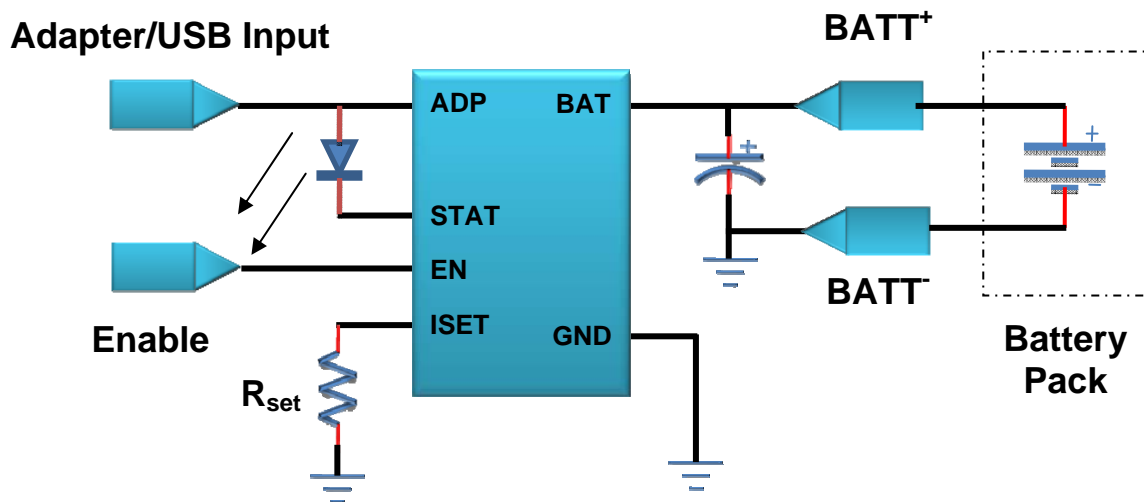

Figure 1, Typical Application Diagram

## Module Description

Single cell lithium-ion/polymer batteries are becoming the prime choice for portable to ultra portable appliances. Towards that end, the AAT3681A is a high performance battery charger designed to charge single cell lithium-ion/polymer batteries with up to 300mA of current from an external power source. This current may be customized over a wide range from 15mA to 300mA using a single external resistor. This allows the adapter/USB to perform rapid charging in several applications. It is a stand-alone charging solution, with just one external component required for complete functionality. The device precisely regulates the battery charge voltage and current for 4.2V lithium-ion/polymer battery cells.

The device is rated for operation from  $-40^{\circ}\text{C}$  to  $+85^{\circ}\text{C}$ . In the event of operating ambient temperatures exceeding the power dissipation abilities of the device package for a given constant current charge level, the charge control will enter into thermal limit.

A status monitor output pin is provided to indicate the battery charge state by directly driving one external LED. Device junction temperature and charge state are fully monitored for fault conditions.

AAT3681A implements a complete protection system. In the event of an overvoltage or over-temperature failure, the device will automatically shut down, protecting the charging device, control system, and the battery under charge.

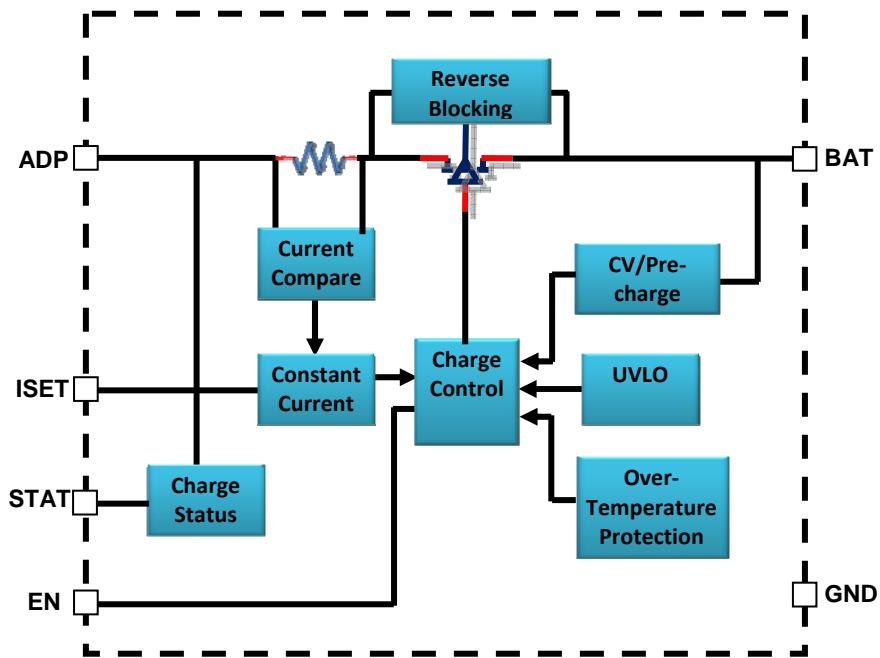

Figure 2, Functional block diagram and pin-out

## Charging Operation

The AAT3681A has four basic modes for the battery charge cycle: pre-conditioning/trickle charge; constant current/fast charge; constant voltage; and end of charge.

### Battery Preconditioning

Before the start of charging, the AAT3681A checks several conditions in order to assure a safe charging environment. The input supply must be above the minimum operating voltage, or under-voltage lockout threshold, for the charging sequence to begin. When these conditions have been met and a battery is connected to the BAT pin, the AAT3681A checks the state of the battery. If the cell voltage is below the preconditioning voltage threshold, the charge control begins preconditioning the cell. The battery preconditioning trickle charge current is equal to the fast charge constant current divided by 10. For example, if the programmed fast charge current is 300mA, then the preconditioning current will be 30mA. Cell preconditioning is a safety precaution for deeply discharged battery cells and also aids in limiting power dissipation in the pass transistor when the voltage across the device is at the greatest potential. Constant Current Charging Battery cell preconditioning continues until the voltage on the BAT pin exceeds the preconditioning voltage threshold. At this point, the device begins the constant current charging phase. The charge constant current amplitude is programmed by the user via the set resistor. The AAT3681A remains in the constant current charge mode until the battery reaches the voltage regulation point.

### Constant Voltage Charging

The system transitions to a constant voltage charging mode when the battery voltage reaches the output charge regulation threshold during the constant current fast charge phase. The regulation voltage level is factory programmed to 4.2V ( $\pm 0.5\%$ ). Charge current in the constant voltage mode drops as the battery cell under charge reaches its maximum capacity.

### End of Charge Cycle Termination and Recharge Sequence

When the charge current drops to 10% of the programmed fast charge current level in the constant voltage mode, the device terminates charging and goes into a sleep state. The charger will remain in a sleep state until the battery voltage decreases to a level below the battery recharge voltage threshold. Consuming very low current in sleep state, the AAT3681A minimizes battery drain when it is not charging. This feature is particularly useful in applications where the input supply level may fall below the battery charge or under-voltage lockout level. In such cases where the AAT3681A input voltage drops, the device will enter sleep state and automatically resume charging once the input supply has recovered from the fault condition.

### Thermal Considerations for Designers

The AAT3681A is offered in a SC70JW-8 package which can provide up to 687mW of power dissipation when it is properly bonded to a printed circuit board and has a maximum thermal resistance of 160°C/W. Many considerations should be taken into account when designing the printed circuit board layout, as well as the placement of the charger IC package in proximity to other heat generating devices in a given application design. The ambient temperature around the charger IC will also have an effect on the thermal limits of a battery charging application. The maximum limits that can be expected for a given ambient condition can be estimated by the following discussion.

First, the maximum power dissipation for a given situation should be calculated:

$$P_{D(MAX)} = \frac{(T_{J(MAX)} - T_A)}{\theta_{JA}}$$

Where:

$P_{D(MAX)}$  = Maximum Power Dissipation (W)

$\theta_{JA}$  = Package Thermal Resistance (°C/W)

$T_{J(MAX)}$  = Maximum Device Junction Temperature (°C) [135°C]

$T_A$  = Ambient Temperature (°C)

Next, the power dissipation can be calculated by the following equation:

$$P_D = (V_{IN} - V_{BAT}) \bullet I_{CH} + V_{IN} \bullet I_{OP}$$

Where:

$P_D$  = Total Power Dissipation by the Device

$V_{IN}$  = Input Voltage

$V_{BAT}$  = Battery Voltage as Seen at the BAT Pin

$I_{CH}$  = Constant Charge Current Programmed for the Application

$I_{OP}$  = Quiescent Current Consumed by the Charger IC for Normal Operation [0.5mA]

By substitution, we can derive the maximum charge current before reaching the thermal limit condition (thermal cycling). The maximum charge current is the key factor when designing battery charger applications.

$$I_{CH(MAX)} = \frac{(P_{D(MAX)} - V_{IN} \bullet I_{OP})}{V_{IN} - V_{BAT}}$$

$$I_{CH(MAX)} = \frac{\frac{(T_{J(MAX)} - T_A)}{\theta_{JA}} - V_{IN} \bullet I_{OP}}{V_{IN} - V_{BAT}}$$

In general, the worst condition is the greatest voltage drop across the charger IC, when battery voltage is charged up to the preconditioning voltage threshold.

### Protection Circuitry; Over-Voltage Protection

An over-voltage event is defined as a condition where the voltage on the BAT pin exceeds the maximum battery charge voltage and is set by the over-voltage protection threshold. If an over-voltage condition occurs, the AAT3681A charge control will shut down the device until voltage on the BAT pin drops below OVP voltage level. The AAT3681A will resume normal charging operation after the over-voltage condition is removed.

### Protection Circuitry; Over-Temperature Shutdown

The AAT3681A has a thermal protection control circuit which will shut down charging functions should the internal die temperature exceed the preset thermal limit threshold. Once the internal die temperature falls below the thermal limit, normal operation will resume the previous charging state.

### Programmability of Charge Current

The constant current charge level, is user programmed with a set resistor placed between the ISET pin and ground. The accuracy of the fast charge, as well as the preconditioning trickle charge current, is dominated by the tolerance of the set resistor used. For this reason,

a 1% tolerance metal film resistor is recommended for the set resistor function. Fast charge constant current levels range from 15mA to 300mA.

## Conclusion

- AAT3681A offers battery charger full functionality in a plug-and-play format. Only one external component is needed for full operation.
- The device offers excellent price/performance value
- A small footprint of 2mm x 2.1mm offers exceptional PCB savings.
- The device is suitable for applications ranging from Bluetooth® Headsets to MP3 players to wrist watches.
- The AAT3681A joins a large family of varied complexity and options from Analogic Tech.

For complete product information, please visit:

<http://www.analogictech.com/products/ProductDisplay.aspx?ProductID=162>

© Advanced Analogic Technologies, Inc. (November 2007)

AnalogicTech and the AnalogicTech logo are trademarks of Advanced Analogic Technologies Incorporated. All other brand and product names appearing in this document are registered trademarks or trademarks of their respective holders.